

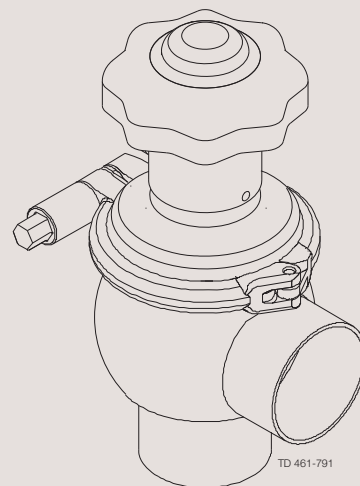

# Instruction Manual

## Unique Single Seat Valve - Manually Operated

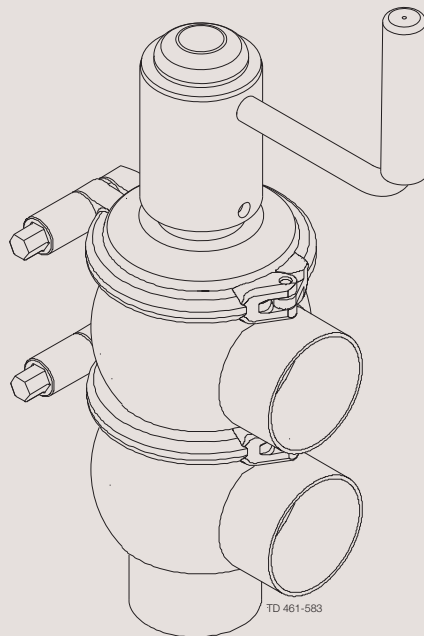

ESE00523-EN7

2020-02

Original manual



The information herein is correct at the time of issue but may be subject to change without prior notice

<b>1. EC Declaration of Conformity</b> .....	<b>4</b>
<b>2. Safety</b> .....	<b>5</b>
2.1. Important information .....	5
2.2. Warning signs .....	5
2.3. Safety precautions .....	6
<b>3. Installation</b> .....	<b>7</b>
3.1. Unpacking/delivery .....	7
3.2. General installation .....	8
3.3. Welding .....	9
3.4. Recycling information .....	9
<b>4. Operation</b> .....	<b>10</b>
4.1. Operation .....	10
4.2. Troubleshooting .....	12
4.3. Recommended cleaning .....	13
<b>5. Maintenance</b> .....	<b>15</b>
5.1. General maintenance .....	15
5.2. Dismantling the valve .....	17
5.3. Plug seal replacement .....	17
5.4. Valve assembly .....	18
<b>6. Technical data</b> .....	<b>19</b>
6.1. Technical data .....	19
<b>7. Parts list and service kits</b> .....	<b>21</b>
7.1. Drawing .....	21
7.2. Unique Single Seat Valve - Manual Operated Shut-off Valve .....	22
7.3. Unique Single Seat Valve - Manual Operated Change-over Valve .....	24

# 1 EC Declaration of Conformity

Revision of Declaration of Conformity: 29/12-09

Alfa Laval Kolding A/S  
Company Name

Albuen 31, DK-6000 Kolding, Denmark  
Address

+45 79 32 22 00  
Phone No.

hereby declare that

Unique Single Seat Valve  
Designation

Manually Operated  
Type

is in conformity with the following directives:

- Machinery Directive 2006/42/EC
- Pressure Equipment Directive 2014/68/EU category 1 and subjected to assessment procedure Module A

The person authorised to compile the technical file is the signer of this document

Global Product Quality Manager  
Pumps, Valves, Fittings and Tank Equipment  
Title

Lars Kruse Andersen  
Name

Kolding  
Place

2016-06-01  
Date

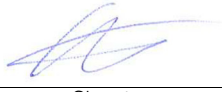
  
Signature



*Unsafe practices and other important information are emphasised in this manual.  
Warnings are emphasised by means of special signs.*

---

### 2.1 Important information

---

**Always read the manual before using the valve!**

**WARNING**

Indicates that special procedures must be followed to avoid serious personal injury.

**CAUTION**

Indicates that special procedures must be followed to avoid damage to the valve.

**NOTE**

Indicates important information to simplify or clarify procedures.

---

### 2.2 Warning signs

---

General warning:



Caustic agents:



## 2 Safety

---

All warnings in this manual are summarised on this page.

Pay special attention to this instructions below so that severe personal injury and/or damage to the valve are avoided.

---

### 2.3 Safety precautions

---

#### Installation:



**Always** read the technical data thoroughly (see chapter 6 Technical data)  
**Never** touch the valve or the pipelines when processing hot liquids or when sterilising  
**Never** dismantle the valve with valve and pipelines under pressure  
**Never** dismantle the valve when it is hot

---

#### Operation:



**Never** dismantle the valve with valve and pipelines under pressure  
**Never** dismantle the valve when it is hot  
**Always** read the technical data thoroughly (see chapter 6 Technical data)  
**Never** touch moving parts if the actuator is supplied with compressed air  
**Always** rinse well with clean water after cleaning



**Always** handle lye and acid with great care

---

#### Maintenance:



**Always** read the technical data thoroughly (see chapter 6 Technical data)  
**Never** service the valve when it is hot  
**Never** service the valve with valve and pipelines under pressure

---

#### Transportation:

**Always** ensure that compressed air is released  
**Always** ensure that all connections are disconnected before attempting to remove the valve from the installation  
**Always** drain liquid out of valves before transportation  
**Always** used predesigned lifting points if defined  
**Always** ensure sufficient fixing of the valve during transportation - if specially designed packaging material is available it must be used

---

The instruction manual is part of the delivery. Study the instructions carefully.  
 The items refer to parts list and service kits section.  
 The valve is supplied as separate parts as standard (for welding).  
 The valve is assembled before delivery, if it is supplied with fittings.

#### 3.1 Unpacking/delivery

##### Step 1

##### CAUTION

Alfa Laval cannot be held responsible for incorrect unpacking.

##### Check the delivery for:

1. Complete valve, shut-off valve or change-over valve.
2. Delivery note.

##### Step 2

##### 2a

##### Shut-off valve:

1. Complete handle.
2. Bonnet (20).
3. Clamp (19).
4. Valve plug (23).
5. Valve body (22).

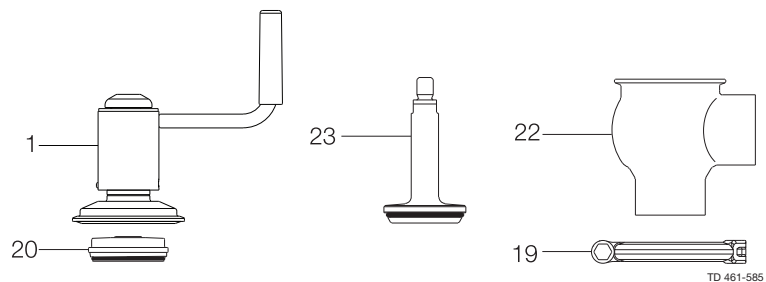

##### 2b

##### Change-over valve:

1. Complete actuator.
2. Bonnet (20).
3. 2 x clamps (19).
4. Valve plug (27).
5. Lower valve body (22).
6. Valve seat (28).
7. Upper valve body (26).

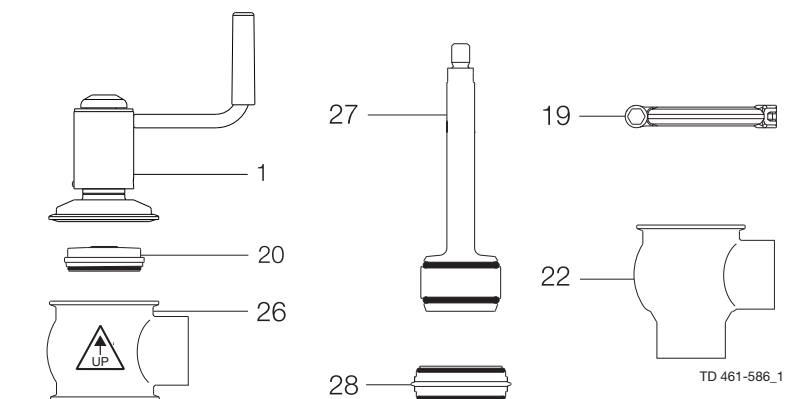

##### Step 3

Remove possible packing materials from the valve/valve parts.  
 Inspect the valve/valve parts for visible transport damage.  
 Avoid damaging the valve/valve parts.

### 3 Installation

Study the instructions carefully and pay special attention to the warnings!  
The valve has welding ends as standard but can also be supplied with fittings.

#### 3.2 General installation

##### Step 1



**Always** read the technical data carefully.  
See chapter 6 Technical data.

##### CAUTION

Alfa Laval cannot be held responsible for incorrect installation.

##### Step 2



**Never** touch moving parts during operation.

Moving parts!

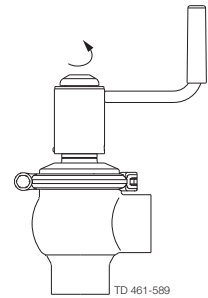

##### Step 3

It is recommended to install the valve so that the flow is against the closing direction to avoid water hammering.

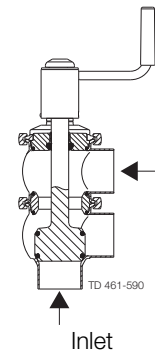

Avoid water hammering!

Inlet

##### Step 4

Avoid stressing the valve.

**Pay special attention to:**

- Vibrations.
- Thermal expansion of the pipelines.
- Excessive welding.
- Overloading of the pipelines.

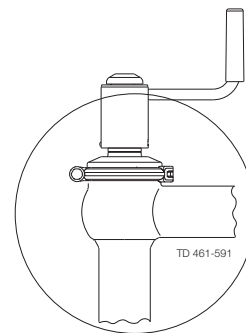

Risk of damage!



Study the instructions carefully.

The valve is supplied as separate parts to facilitate the welding.

The items refer to the parts list and service kits section.

Check the valve for smooth operation after welding.

### 3.3 Welding

#### Step 1

**Always** install valves with more than one valve body so that the seals between the valve bodies can be replaced. Do not weld more than one valve body into the system.

Measurement A is depending on body combination and piping solution.

It is recommended to fit sufficient clamps/unions to be able to disassemble the valve for servicing

Please see actual PD-sheet for further information.

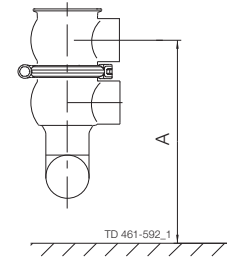

#### Step 2

Assemble the valve in accordance with the steps on page 18.

**Pay special attention to the warnings!**

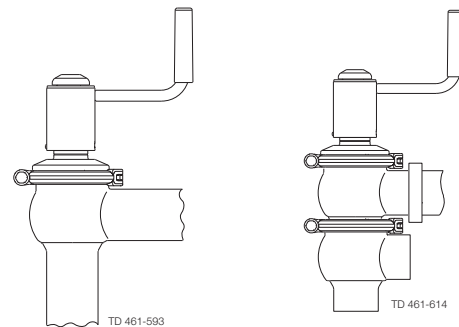

#### Step 3

##### Pre-use check:

Open and close the valve several times to ensure that it operates smoothly.

**Pay special attention to the warnings!**

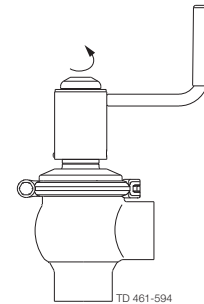

### 3.4 Recycling information

#### • Unpacking

- Packing material consists of wood, plastics, cardboard boxes and in some cases metal straps
- Wood and cardboard boxes can be re-used, recycled or used for energy recovery
- Plastics should be recycled or burnt at a licensed waste incineration plant
- Metal straps should be sent for material recycling

#### • Maintenance

- During maintenance, oil and wearing parts in the machine are replaced
- All metal parts should be sent for material recycling
- Worn out or defective electronic parts should be sent to a licensed handler for material recycling
- Oil and all non-metal wear parts must be disposed off in agreement with local regulations

#### • Scrapping

- At end of use, the equipment must be recycled according to the relevant, local regulations. Besides the equipment itself, any hazardous residues from the process liquid must be considered and dealt with in a proper manner. When in doubt, or in the absence of local regulations, please contact your local Alfa Laval sales company

## 4 Operation

Study the instructions carefully and pay special attention to the warnings!  
Ensure that the valve operates smoothly.  
The items refer to the parts list and service kits section.

### 4.1 Operation

#### Step 1



**Always** read the technical data carefully.  
See chapter 6 Technical data.

#### CAUTION

Alfa Laval cannot be held responsible for incorrect operation.

#### Step 2



**Never** touch the valve or the pipelines when processing hot liquids  
or when sterilising.

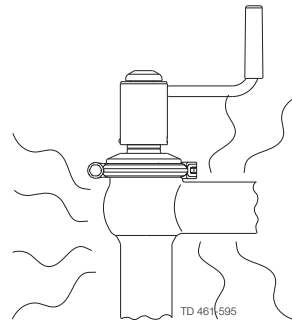

**Burn hazard!**

#### Step 3



**Never** touch moving parts during operation.

**Moving parts!**

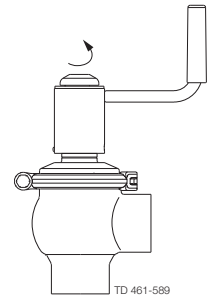

#### Step 4

##### Lubrication of valves:

1. Ensure smooth movement between lip seal (25) and plug stem (23, 27).
2. Lubricate the lip seal with Klüber Paraliq GTE 703 if necessary (see page 15).

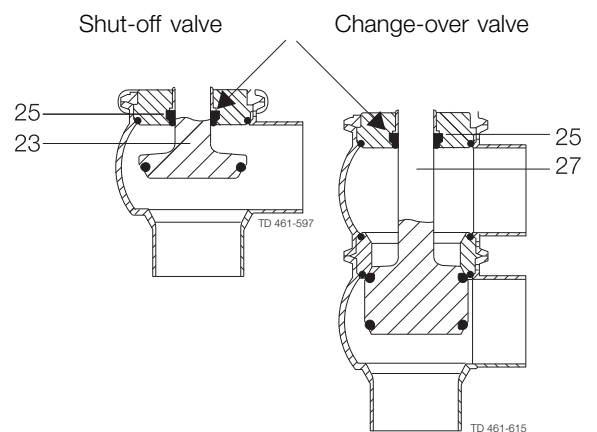

*Study the instructions carefully and pay special attention to the warnings!*

*Ensure that the valve operates smoothly.*

*The items refer to the parts list and service kits section.*

---

### Step 5

#### Lubrication of actuator

1. Ensure smooth movement of the crank mechanism (the crank is lubricated before delivery).
2. Lubricate all seals with Molykote Longterm 2 plus if necessary.

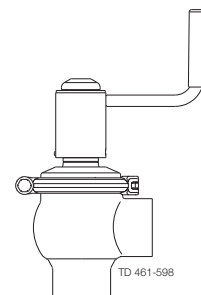

## 4 Operation

Pay attention to possible faults. Study the instructions carefully.  
The items refer to the parts list and service kits section.

### 4.2 Troubleshooting

#### NOTE!

Study the maintenance instructions carefully before replacing worn parts - see page 15!

Problem	Cause/result	Repair
External product leakage	Worn or product affected lip seal and/or O-ring	<ul style="list-style-type: none"><li>- Replace the seals</li><li>- Replace with seals of a different rubber grade</li></ul>
Internal product leakage	<ul style="list-style-type: none"><li>- Worn or product affected plug seal</li><li>- Product deposits on the seat and/or plug</li><li>- Product pressure exceeds actuator specification</li></ul>	<ul style="list-style-type: none"><li>- Replace the seal</li><li>- Replace with a seal of a different rubber grade</li><li>- Frequent cleaning</li><li>- Replace with a high pressure actuator</li><li>- Use auxiliary air on the spring side</li><li>- Reduce product pressure</li></ul>
Water hammer	The flow direction is the same as the closing direction	The flow direction should be against the closing direction
The valve does not open/close	Product pressure exceeds actuator specification	Reduce product pressure

The valve is designed for cleaning in place (CIP).  
 Study the instructions carefully and pay special attention to the warnings!  
 NaOH = Caustic Soda.  
 HNO<sub>3</sub> = Nitric acid.

### 4.3 Recommended cleaning

#### Step 1



Always handle lye and acid with great care.

Caustic danger!



Always use rubber gloves!



Always use protective goggles!

#### Step 2



Never touch the valve or the pipelines when sterilising.

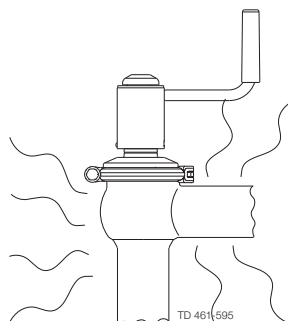

Burn hazard!



#### Step 3

Clean the plug and the seats correctly.  
 Pay special attention to the warnings!  
 Lift and lower valve plug momentarily!

Shut-off valve

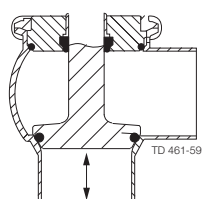

Change-over valve

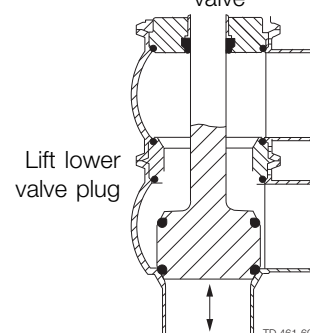

Lift lower valve plug

#### Step 4

Examples of cleaning agents:

Use clean water, free from chlorides.

1. 1% by weight NaOH at 70° C

1 kg NaOH + 100 l water = Cleaning agent.

2.2 l 33% NaOH + 100 l water = Cleaning agent.

2. 0.5% by weight HNO<sub>3</sub> at 70° C

0.7 l 53% HNO<sub>3</sub> + 100 l water = Cleaning agent.

## 4 Operation

---

*The valve is designed for cleaning in place (CIP).*

*Study the instructions carefully and pay special attention to the warnings!*

*NaOH = Caustic Soda.*

*HNO<sub>3</sub> = Nitric acid.*

---

### Step 5

1. Avoid excessive concentration of the cleaning agent.
2. Adjust the cleaning flow to the process.
3. **Always** rinse well with clean water after the cleaning.

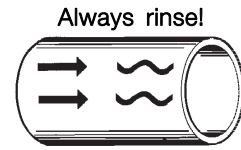

Clean water    Cleaning agents

---

### Step 6

#### NOTE

The cleaning agents must be stored/disposed off in accordance with current regulations/directives.

---

Maintain the valve regularly.  
Study the instructions carefully and pay special attention to the warnings!  
Always keep spare rubber seals and lip seals in stock.

### 5.1 General maintenance

#### Step 1



**Always** read the technical data carefully.  
See chapter 6 Technical data.

#### NOTE

All scrap must be stored/discharged in accordance with current rules/directives.

#### Step 2



**Never** service the valve when it is hot.



**Never** service the valve with valve and pipelines under pressure.

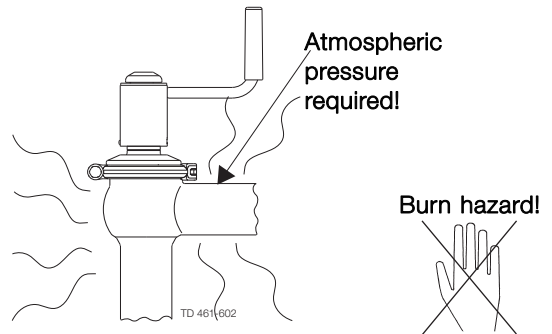

#### Step 3



**Never** stick your fingers through the valve ports if the actuator is supplied with compressed air.

**Never** touch the moving parts if the actuator is supplied with compressed air.

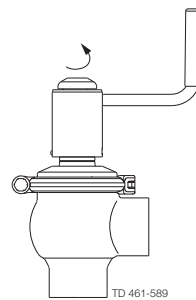

## 5 Maintenance

Maintain the valve regularly.

Study the instructions carefully and pay special attention to the warnings!

Always keep spare rubber seals and lip seals in stock.

Below are some guidelines for maintenance and lubrication intervals. Please note that the guidelines are for normal working conditions in one shift.

	<b>Product wetted seals</b>
Preventive maintenance	<b>Replace after 12 months depending on working conditions</b>
Maintenance after leakage (leakage normally starts slowly)	<b>Replace at the end of the day</b>
Planned maintenance	<ul style="list-style-type: none"> <li>- Regular inspection for leakage and smooth operation</li> <li>- Keep a record of the valve</li> <li>- Use the statistics for inspection planning</li> </ul> <b>Replace after leakage</b>
Lubrication	<b>Before fitting</b> Klüber Paraliq GTE 703 or similar USDA H1 approved oil/grease

### Pre-use check:

Open and close the valve several times to ensure that it operates smoothly.

**Pay special attention to the warnings!**

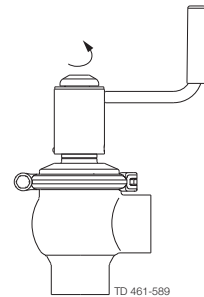

TD 461-589

### Recommended spare parts

Service kits (see page 21)



Study the instructions carefully. The items refer to the parts list and service kits section. Handle scrap correctly.

### 5.2 Dismantling the valve

#### Step 1

##### 1a

##### Shut-off valve:

1. Remove cap, loosen screw and remove the washer by sliding it sideways.
2. Loosen and remove clamp.
3. Lift away the crank.
4. Remove valve plug.
5. Remove O-ring, lip seal and bushing in bonnet.  
(Use bushing tool and rubber mallet).

**Note!** Be careful not to damage the bushing.

**Pay special attention to the warnings!**

**Note!** For plug seal replacement please see 17.

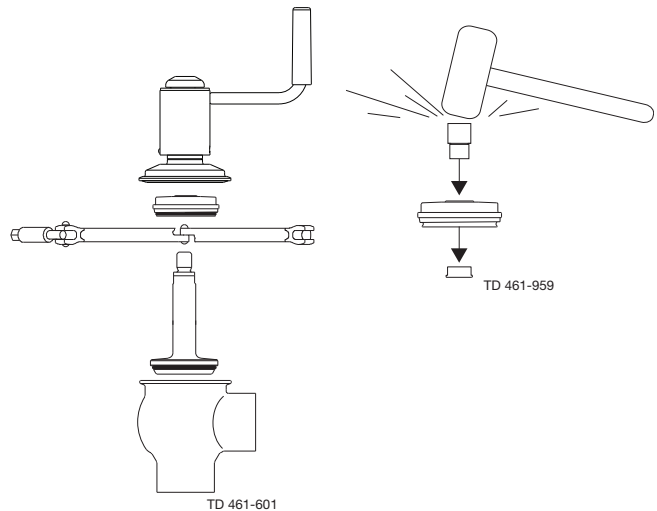

##### 1b

##### Change-over valve:

1. Loosen and remove lower clamp.
2. Lift away the crank and upper valve body.
3. Remove cap, loosen screw and remove the washer by sliding it sideways.
4. Loosen and remove upper clamp.
5. Lift away the crank.
6. Remove valve body.
7. Remove seat and O-rings.
8. Remove O-ring, lip seal and bushing in bonnet.  
(Use bushing tool and rubber mallet.  
See drawing, step 1a).

**Note!** Be careful not to damage the bushing.

**Pay special attention to the warnings!**

**Note!** For plug seal replacement please see 17.

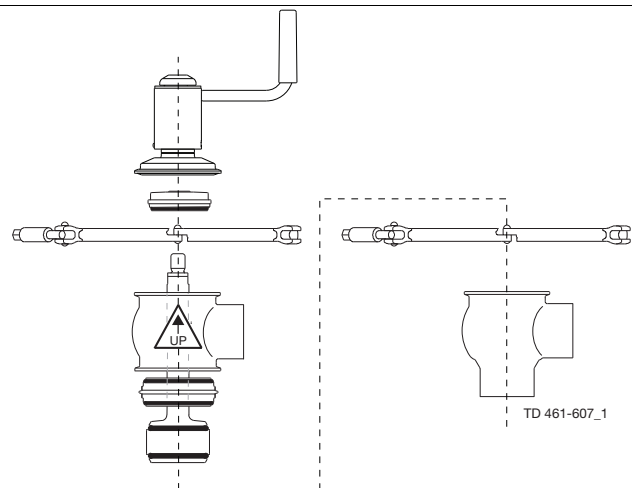

### 5.3 Plug seal replacement

1. Remove old seal ring using a knife, screwdriver or similar.  
Be careful not to damage metal parts.
2. Pre-mount plug seal without pressing it into the groove.
3. Squeeze plug seal into the groove using opposite pressure points.
4. Release compressed air behind plug seal.

**Note!** For plug seal replacement please read instruction in service kit.

## 5 Maintenance

---

*Study the instructions carefully. The items refer to the parts list and service kits section. Handle scrap correctly.*

---

### 5.4 Valve assembly

---

Reverse order of 5.2 Dismantling the valve.

Lubricate O-ring (21) and lip seal (25) with Klüber Paraliq GTE 703.

Remember to tighten spindle and plug to a torque of **30Nm**. (to use two 17mm spanners)

If there are vibrations in the pipeline Alfa Laval recommended using loctite no. 243.

The clamps thread must be lubricated before tightening - max. torque for the clamps is 10-12 Nm.

**Note!** Do not forget to screw in lower set screw (7) when assembling the valve.

It acts as a stroke stop. Without this screw the valve can be opened so far that the crank comes off.

In some valve sizes the flats on the plug stem may enter into the lip seal, which will then leak.

---

*It is important to observe the technical data during installation, operation and maintenance.  
Inform all personnel about the technical data.*

### 6.1 Technical data

Data - valve	
Max. product pressure	1000 kPa (10 bar).
Min. product pressure	Full vacuum (depending on product specifications).
Temperature range	-10° C to + 140° C (standard EPDM seal).
Materials - valve/crank mechanism	
Product wetted steel parts	1.4404 (316L) (internal Ra < 0.8 µm).
Other steel parts	1.4301 (304).
Plug seal	EPDM / PTFE (TR2).
Other product wetted seals	EPDM (standard).
Optional product wetted seals	HNBR and FPM.

#### Noise

One metre away from and 1.6 metres above the exhaust the noise level of a valve actuator will be approximately 77db (A) without noise damper and approximately 72 db (A) with damper - measured at 7 bar air-pressure.



## 7 Parts list and service kits

The drawing shows Unique Single Seat Valve - Manually operated.  
The items refer to the parts list in the following sections

### 7.1 Drawing

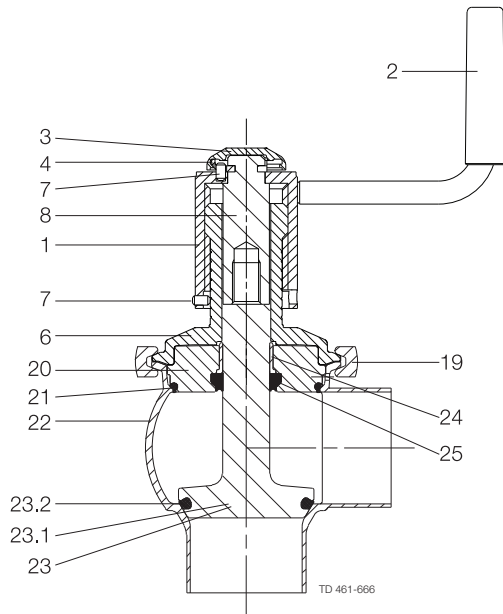

Shut-off

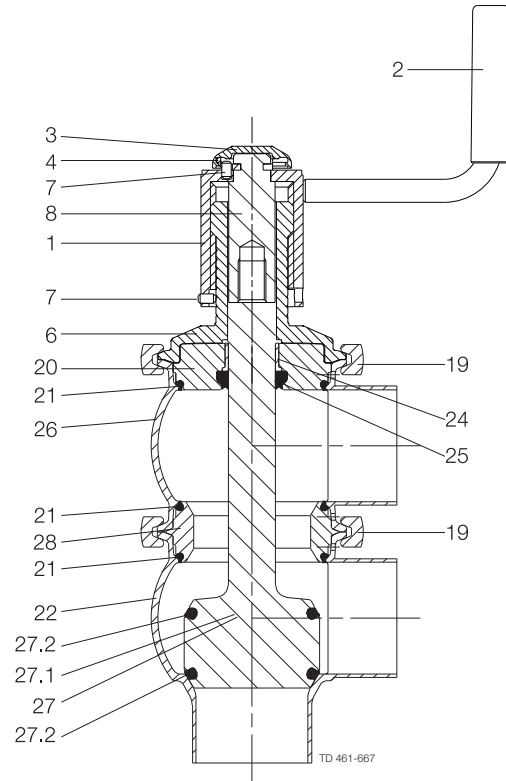

Change-over

## 7 Parts list and service kits

The drawing shows Unique Single Seat Valve - Manual operated, Shut-off.  
The items refer to the parts lists in the following sections

### 7.2 Unique Single Seat Valve - Manual Operated Shut-off Valve

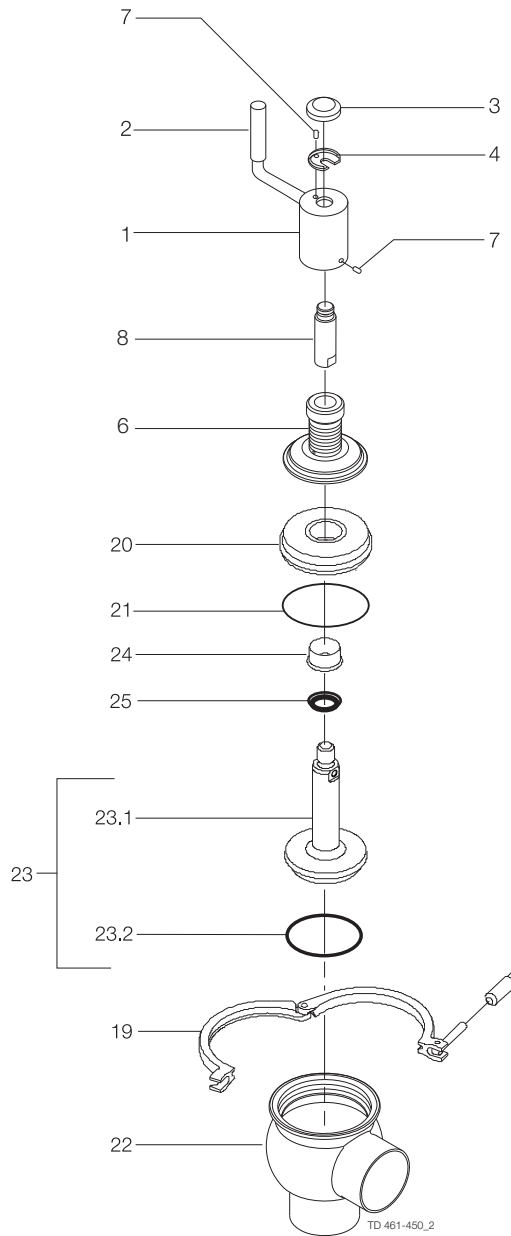

## 7 Parts list and service kits

The drawing shows Unique Single Seat Valve - Manual operated, Shut-off.  
The items refer to the parts lists in the following sections

### Parts list

Pos.	Qty	Denomination
		Crank mechanism complete
		O-ring set (10 pcs.) EPDM
		O-ring set (10 pcs.) HNBR
		O-ring set (10 pcs.) FPM
		Lip seal set (10 pcs.) EPDM
		Lip seal set (10 pcs.) HNBR
		Lip seal set (10 pcs.) FPM
		Plug seat set (10 pcs.) EPDM
		Plug seat set (10 pcs.) HNBR
		Plug seat set (10 pcs.) FPM
1	1	Crank
2	1	Handle (included in pos. 1 )
3	1	Cap
4	1	Washer
6	1	Guide
7	2	Set screw
8	1	Stem holder
19	1	Clamp
20	1	Bonnet
21 <input type="checkbox"/>	1	O-ring
22	1	Valve body
23	1	Plug
23.1	1	Plug
23.2 <input type="checkbox"/>	1	Plug seal
24	1	Bushing
25 <input type="checkbox"/>	1	Lip seal

### Service kits

Denomination	DN 25 25 mm	DN 40 38 mm	DN 50 51 mm	DN 65 63.5 mm	DN 80 76.1 mm	DN 100 101.6 mm
--------------	----------------	----------------	----------------	------------------	------------------	--------------------

#### Service kit for product wetted parts, standard

<input type="checkbox"/>	Service kit, EPDM .....	9611926501	9611926502	9611926503	9611926504	9611926505	9611926506
<input type="checkbox"/>	Service kit, HNBR .....	9611926507	9611926508	9611926509	9611926510	9611926511	9611926512
<input type="checkbox"/>	Service kit, FPM .....	9611926513	9611926514	9611926515	9611926516	9611926517	9611926518

Parts marked with  are included in the service kits (product wetted parts)

Recommended spare parts: Service kits.

TD 900-383/2

## 7 Parts list and service kits

The drawing shows Unique Single Seat Valve - Manual operated, Change-over.  
The items refer to the parts lists in the following sections

### 7.3 Unique Single Seat Valve - Manual Operated Change-over Valve

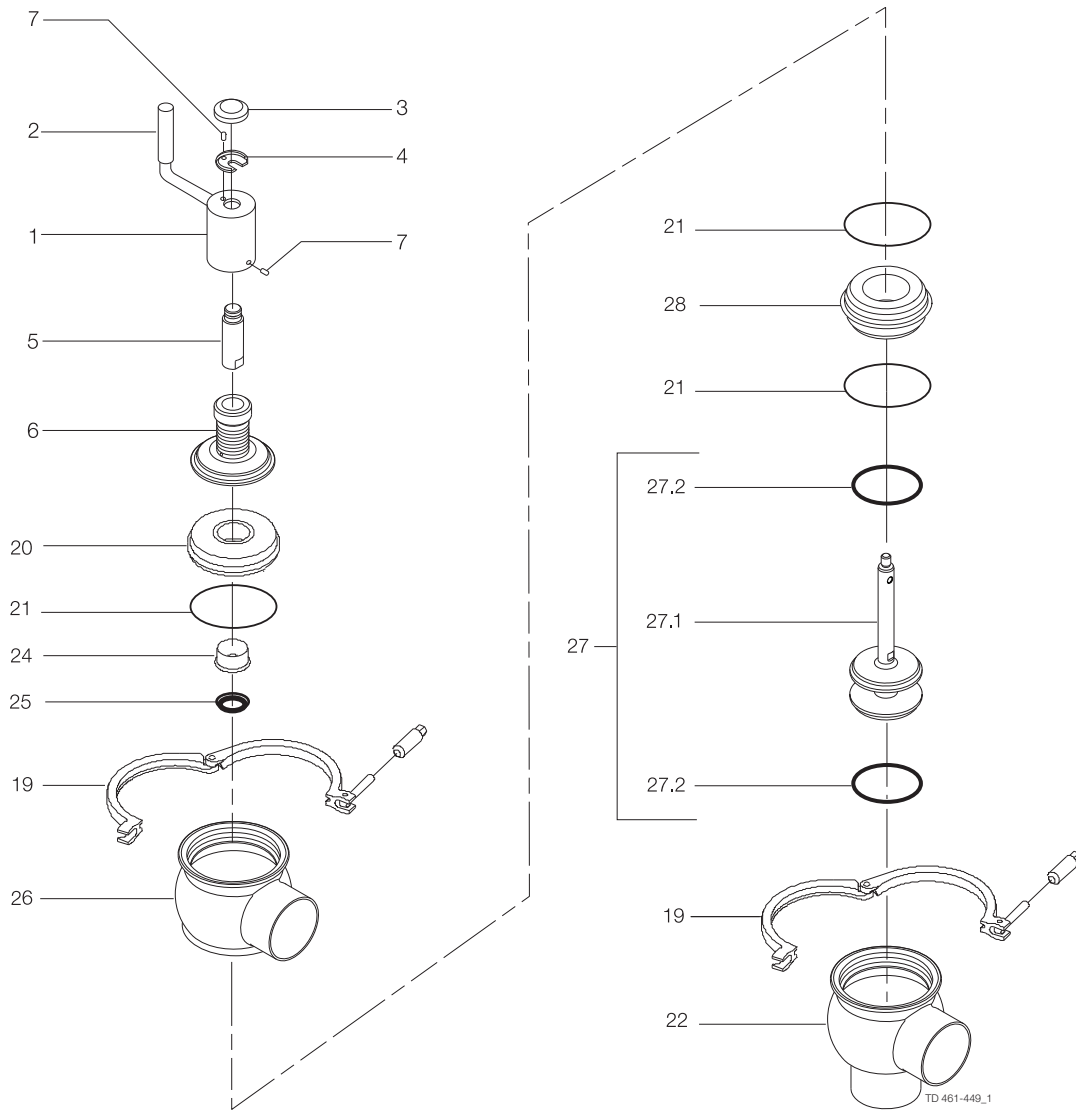



## 7 Parts list and service kits

The drawing shows Unique Single Seat Valve - Manual operated, Change-over.  
The items refer to the parts lists in the following sections

### Parts list

Pos.	Qty	Denomination
		Crank mechanism complete
		O-ring set (10 pcs.) EPDM
		O-ring set (10 pcs.) HNBR
		O-ring set (10 pcs.) FPM
		Lip seal set (10 pcs.) EPDM
		Lip seal set (10 pcs.) HNBR
		Lip seal set (10 pcs.) FPM
		Plug seal set (10 pcs.) EPDM
		Plug seal set (10 pcs.) HNBR
		Plug seal set (10 pcs.) FPM
1	1	Crank
2	1	Handle (included in pos. 1 )
3	1	Cap
4	1	Washer
6	1	Guide
7	2	Set screw
8	1	Stem holder
19	2	Clamp
20	1	Bonnet
21 <input type="checkbox"/>	3	O-ring
22	1	Valve body
24	1	Bushing
25 <input type="checkbox"/>	1	Lip seal
26	1	Valve body
27	1	Plug
27.1	1	Plug
27.2 <input type="checkbox"/>	2	Plug seal
28	1	Seat

### Service kits

Denomination	DN 25 25 mm	DN 40 38 mm	DN 50 51 mm	DN 65 63.5 mm	DN 80 76.1 mm	DN 100 101.6 mm
--------------	----------------	----------------	----------------	------------------	------------------	--------------------

#### Service kit for product wetted parts, standard

<input type="checkbox"/>	Service kit, EPDM .....	9611926579	9611926580	9611926581	9611926582	9611926583	9611926584
<input type="checkbox"/>	Service kit, HNBR .....	9611926585	9611926586	9611926587	9611926588	9611926589	9611926590
<input type="checkbox"/>	Service kit, FPM .....	9611926591	9611926592	9611926593	9611926594	9611926595	9611926596

Parts marked with  are included in the service kits (product wetted parts)

Recommended spare parts: Service kits.

TD 900-383/2

**How to contact Alfa Laval**

Contact details for all countries are continually updated on our website.

Please visit [www.alfalaval.com](http://www.alfalaval.com) to access the information directly.

© Alfa Laval Corporate AB

This document and its contents is owned by Alfa Laval Corporate AB and protected by laws governing intellectual property and thereto related rights. It is the responsibility of the user of this document to comply with all applicable intellectual property laws. Without limiting any rights related to this document, no part of this document may be copied, reproduced or transmitted in any form or by any means (electronic, mechanical, photocopying, recording, or otherwise), or for any purpose, without the expressed permission of Alfa Laval Corporate AB. Alfa Laval Corporate AB will enforce its rights related to this document to the fullest extent of the law, including the seeking of criminal prosecution.