



Alfa Laval LKB UltraPure

Butterfly valves

Introduction

The Alfa Laval LKB UltraPure Butterfly Valve is a hygienic in-line valve for routing low and medium-viscosity liquids in stainless steel pipe systems. The LKB UltraPure is available with a standard handle with spring-locking action for straightforward manual operation or with a pneumatic actuator for pneumatic operation.

Application

This in-line butterfly valve is designed for on-off duties in high-purity applications across the personal care, biotechnology and pharmaceutical industries.

Benefits

- Versatile, highly modular design
- Competitively priced alternative to diaphragm valves in certain applications
- Full transparency and traceability of the entire supply chain due to the Alfa Laval Q-doc documentation package
- Easy to configure in either a manual version or a pneumatic version

Standard design

The LKB UltraPure Butterfly Valve consists of two valve body halves, valve disc, and bushings for the disc stem and seal ring, assembled by means of screws and nuts. The valve can also be fitted with the Alfa Laval ThinkTop® V50 and V70 for sensing and control of the valve.

Working principle

The Alfa Laval LKB UltraPure Butterfly Valve is either controlled remotely by means of an pneumatic actuator or manually by means of a handle.

For pneumatic operation, an actuator converts axial piston motion into a 90° rotation of the shaft. The actuator torque increases as the valve disc comes into contact with the seal ring of the butterfly valve to secure proper closing of the valve seat. The actuator comes in three standard versions: normally closed (NC); normally open (NO); and, air/air activated (A/A). Two actuator sizes, $\varnothing 85$ mm and $\varnothing 133$ mm, cover all valve sizes and are available in two versions, LKLA and LKLA-T (T for mounting of indication or control unit on the actuator).

For manual operation, the handle mechanically locks the valve in open or closed position. Handles are available in two positions, four positions, regulating 90° position, and multi-position. The valve can be supplied either with welding connections or clamp connections and can be mounted with indication units for feedback on the valve position (open or closed).



TECHNICAL DATA

Valve	
Max. product pressure:	1000 kPa (10 bar)
Min. product pressure:	Full vacuum
Temperature range:	-10°C to + 140°C (EPDM) However max. 95°C when operating the valve (All seals)
Actuator	
Max. air pressure:	600 kPa (6 bar)
Min. air pressure, NC and NO:	400 kPa (4 bar)
Temperature range:	-25°C to +90°C
Air consumption (litres free air):	
- ø85 mm:	0.24 x p (bar)
- ø133 mm:	0.95 x p (bar)
Weight:	
- ø85 mm:	3 kg.
- ø133 mm:	12 kg



PHYSICAL DATA

Materials	
Product wetted steel part	1.4404 (316L) acc. to EN 10088
Other steel parts	1.4301 (304) acc. to EN 10088
Bushings for valve disc	PVDF

Elastomers	
Product wetted seals	EPDM acc. to FDA and USP Class VI

Connections	
Weld ends**	Matching tubes and fittings: ISO 2037 / DIN / ASME BPE Acc. to ISO, DIN or ASME BPE
Clamp ends	Matching tubes and fittings: ISO 2037 / DIN / ASME BPE Acc. to ISO, DIN or ASME BPE

** Weld ends on ASME BPE valves are according to ASME BPE 2009 316L Table DT-3 with low sulfur and suitable for orbital welding

Actuator	
Actuator body:	1.4307 (304L)
Piston:	Light alloy Air/air version (for ø85 mm: Bronze)
Seals:	NBR
Housing for switches:	PPO

Surface specification (Product wetted steel parts)

ISO 2037 / DIN:	
Internal:	0.5 µm
ASME BPE designation:	SF1
External:	Semi-bright
ASME BPE*:	
Internal:	0.5 µm
ASME BPE designation:	SF1
External:	Semi-bright
ASME BPE*:	
Internal:	0.4 µm electro polish
ASME BPE designation:	SF4
External:	Semi-bright

* According to ASME BPE 2009 table SF-3

Options

- A. Product wetted seals: FPM (acc. to FDA and USP Class VI), Q and PFA
 - B. ThinkTop® for control and indication.*
 - C. Indication unit with micro switches.*
 - D. Indication unit with inductive proximity switches.*
 - E. Indication unit with Hall proximity switches.*
 - F. Explosion proof indication unit with inductive proximity switches.*
 - G. Bracket for actuator.
 - H. Handle with two or four positions.
 - I. Handle for electrical position indication.
 - J. Handle with infinite intermediate positions.
 - K. Multipositioning handle**.
 - L. Lockable Multiposition Handle. Padlock can be mounted as shown in fig. 3.
- Note!** Padlock is not delivered.
- M. Special cap for 90° turned handle position.
 - N. Service tool for actuator.
 - O. Service tool for fitting 25-38 mm (DN25 - DN40) valve discs.

* For further information see Product Catalogue chapter "Control & Indication".

** A padlock can be mounted on the Lockable Multiposition Handle as shown in the opposite figure.

Note! Padlock is not delivered.

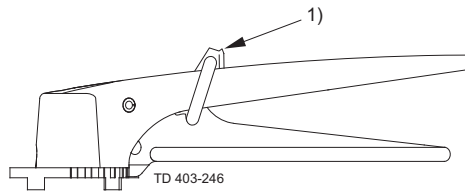

Fig. 1. Lockable Multiposition Handle with padlock.

1. Padlock

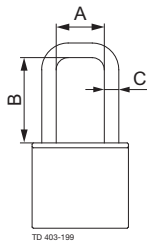

Fig.2. Dimensions - padlock.

- A. Min. 20 mm
- B. Min. 35 mm
- C. ø6 mm

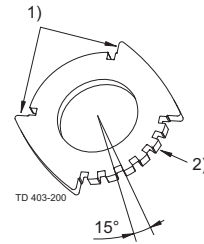

Fig. 3 Positioning cap.

- 1. On/Off
- 2. Multi positioning

Note for Ultra Pure ASME BPE clamp valve (size 1" - 2½")!

Installation and removal of some clamp rings is easiest by removal of the lockable multi position handle first.

Documentation

All valves are delivered with Alfa Laval Q-doc.

Note!

For further details, see also ESE01699.

Capacity/Pressure drop diagrams

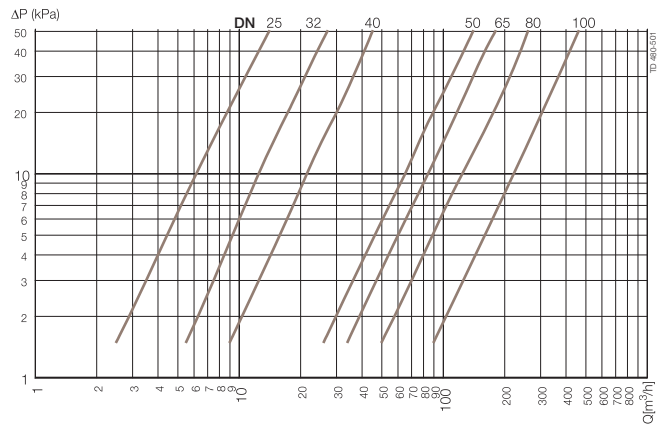
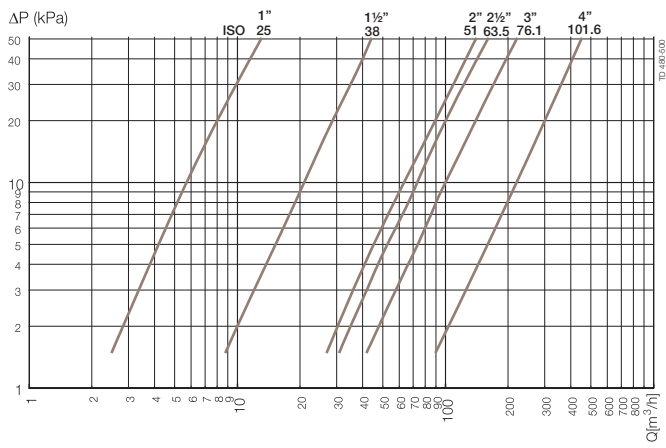

NOTE!

For the diagrams the following applies:

Medium: Water (20°C).

Measurement: In accordance with VDI 2173.

Torque diagrams - Actuator

LKLA ø85 mm:

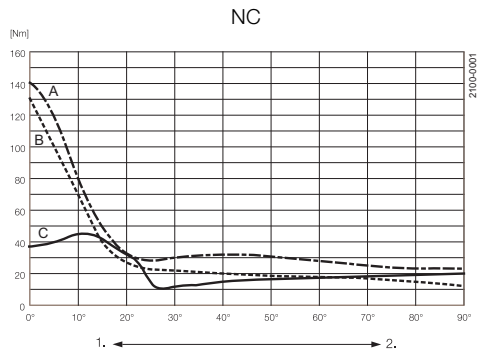

1. Closing - Spring activated 2. Opening - Air activated

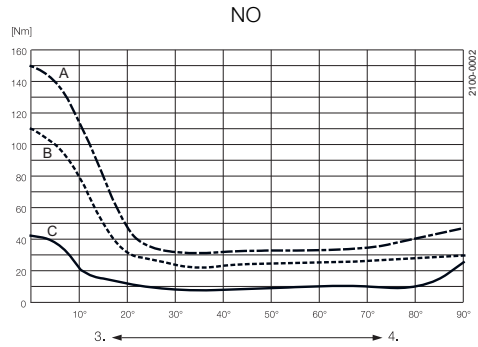

3. Closing - Air activated 4. Opening - Spring activated

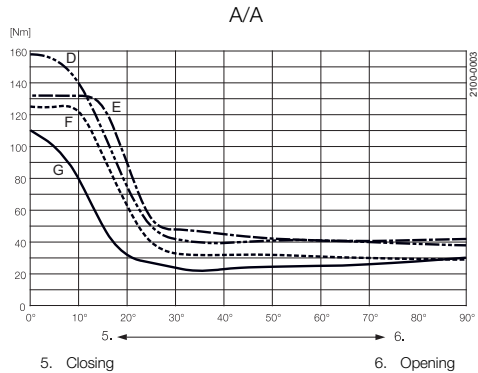

5. Closing 6. Opening

A = 6 bar air pressure
 B = 5 bar air pressure
 C = Closing/opening with spring

LKLA ø133 mm:

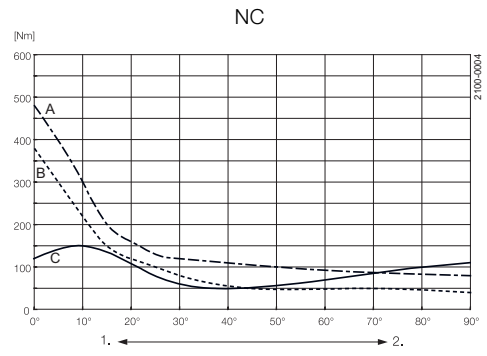

1. Closing - Spring activated 2. Opening - Air activated

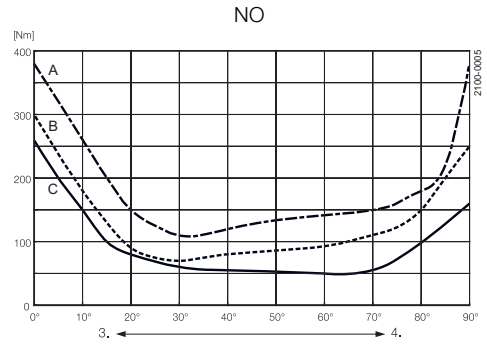

3. Closing - Air activated 4. Opening - Spring activated

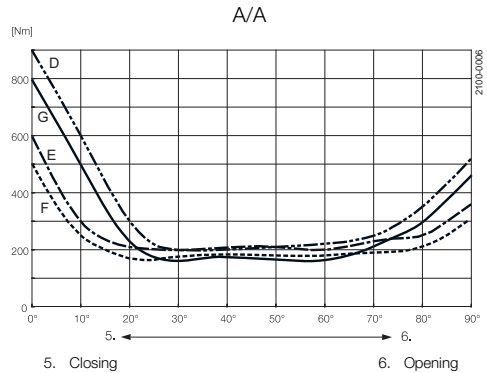

5. Closing 6. Opening

D = 6 bar air pressure connection on top
 E = 6 bar air pressure connection on bottom
 F = 5 bar air pressure connection on top
 G = 5 bar air pressure connection on bottom

Torque values (for rotating the valve disc in a dry seal ring)

Size	Max. Nm
25 mm	15
32 mm	15
38 mm	15
51 mm	20
63.5 mm	25
76 mm	30
101.6 mm	35

Dimensions (mm)

Fig. 1. Dimensions - valve.

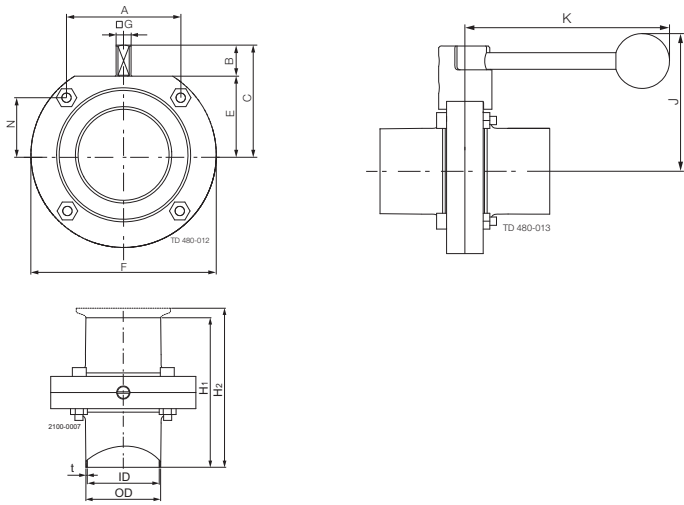
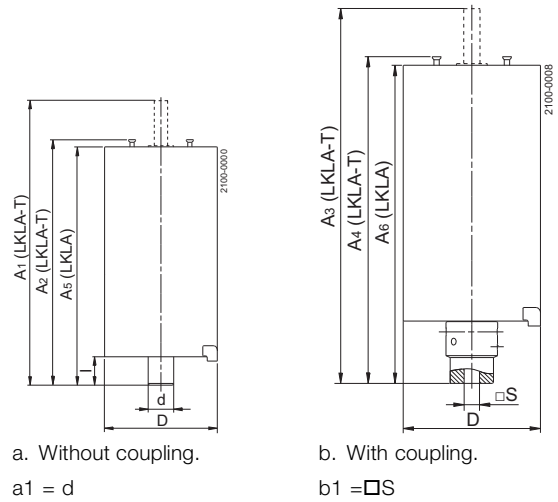

Fig. 2. Dimensions - actuator.



Dimensions (mm)

LKB UltraPure

Size	25	38	51	63.5	76.1	101.6	DN	DN	DN	DN	DN	DN	DN
	mm	mm	mm	mm	mm	mm	25	32	40	50	65	80	100
A	42.00	42.00	61.00	61.00	79.50	106.00	42.00	42.00	42.00	61.00	61.00	79.00	106.00
B	15.50	16.70	16.60	17.50	16.60	16.00	14.70	15.90	16.70	16.60	17.50	16.00	160.00
C	49.00	49.00	58.50	69.50	73.50	93.00	48.00	49.00	54.00	63.00	75.00	79.00	93.00
OD	25.00	38.00	51.00	63.50	76.10	101.60	29.00	35.00	41.00	53.00	70.00	85.00	104.00
ID	22.60	35.60	48.60	60.30	72.90	97.60	26.00	32.00	38.00	50.00	66.00	81.00	100.00
t	1.20	1.20	1.20	1.60	1.60	2.00	1.50	1.50	1.50	1.50	2.00	2.00	2.00
E	32.50	32.50	42.00	52.00	57.00	77.00	33.30	33.30	37.70	46.60	57.30	63.00	77.00
F	78.00	78.00	99.00	117.00	132.00	169.00	79.00	79.00	86.50	105.70	125.00	143.00	169.00
□ G	8	8	8	8	10	12	8	8	8	8	10	10	12
H1	127.00	127.00	132.00	134.00	162.00	180.00	127.00	127.00	127.00	132.00	142.00	164.00	180.00
H2	104.20	104.20	109.20	111.20	176.40	194.40	90.00	90.00	90.00	95.00	118.00	120.00	136.00
J	82.00	82.00	92.00	102.00	107.00	127.00	74.00	74.00	78.00	88.00	98.00	104.00	118.00
K	120.00	120.00	120.00	120.00	162.00	162.00	120.00	120.00	120.00	120.00	162.00	162.00	162.00
N	26.50	26.50	30.50	40.50	43.50	53.00	27.30	27.30	31.70	35.10	45.80	49.50	53.00
Weight (kg)	1.2	1.0	1.5	2.1	3.0	4.7	1.2	1.1	1.3	1.8	3.1	3.5	5.1

NOTE! Weights are for valves with welding ends and handles.

Dimensions (mm) - Actuator

LKLA and LKLA-T:

Valve size	25-63.5 mm DN25-50	76.1 mm DN65-80	101.6 mm DN100	101.6 mm DN100
A ₁	244	242	242	363
A ₂	193	191	191	316
A ₃	244	244	244	337
A ₄	173	173	173	290
A ₅	185	183	183	308
A ₆	165	165	165	282
D	85	85	85	133
d	17	17	17	30
l	16.5	16.5	16.5	34
□ s	8	10	12	12
Function	NC, NO, A/A	NC, NO, A/A	NC, NO, A/A	NC, NO, A/A

900593

Connections

Compressed air

R¹/₈" (BSP), internal thread.

Alfa Laval reserves the right to change specifications without prior notification.

How to contact Alfa Laval

Contact details for all countries are continually updated on our website. Please visit www.alfalaval.com to access the information direct.