



Alfa Laval GJ PF

Fast, Effective Impact Cleaning

Application

The field-proven Alfa Laval GJ PF is part of the world-renowned range of Gamajet high impact tank cleaning devices. It has been proven to provide companies with up to 85% in water, time, energy, and resource savings compared to static spray balls. This device is capable of cleaning tanks with capacities between 18.9 m³ - 94.6 m³. The Alfa Laval GJ PF fits through openings as small as 10 cm and operates at low pressures and flows, cleaning tanks in the ethanol, paper, pulp, chemical, steel, industrial fermentation industry, and many other applications that require high impact cleaning. By implementing this device into their tank cleaning process, companies spend less time cleaning and more time producing.

Working principle

The Gamajet range of high impact tank cleaning devices combine pressure and flow to create high impact cleaning jets. Cleaning occurs at the point at which the concentrated stream impacts the surface. It is this impact and the tangential force that radiates from that point which blasts contaminants from the surface, scouring the tank interior. In conjunction with this impact, the device is engineered to rotate in a precise, repeatable and reliable, 360° pattern. This full-coverage, global indexing pattern ensures the entire tank interior is cleaned, every time.

TECHNICAL DATA

Lubricant Food grade
 Max. throw length 14 - 20 m

Pressure

Working pressure 3 - 28+ bar
 Recommended pressure 4 - 20 bar

Cleaning Pattern

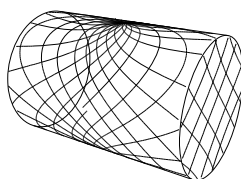

First Cycle

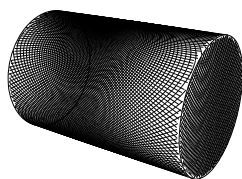

Full Pattern

The above drawings show the cleaning pattern achieved on a cylindrical horizontal vessel. The difference between the first cycle and the full pattern represents the number of additional cycles available to increase the density of the cleaning.



PHYSICAL DATA

Materials

316L, PPS, PTFE, EPDM (FKM and FFKM available).

Temperature

Max. working temperature 90°C
 Max. ambient temperature 140°C

Weight 4.5 kg

Surface finish 0.8 µm

Connections

Standard thread 1½" Rp (BSP) or NPT, female
 Available option 1.5" weld, 1.5" tri-clamp, 1.5" ISO 2037 slip fit, 1.5" DIN R1 slip fit, 1.5" DIN R2 slip fit

Caution

Avoid hydraulic shock, hard and abrasive particles in the cleaning liquid, as this can cause increased wear and/or damage of internal mechanisms. In general, a filter in the supply line is recommended. Do not use for gas evacuation or air dispersion. For steaming we refer to the manual.

Flow Rate 2-nozzle

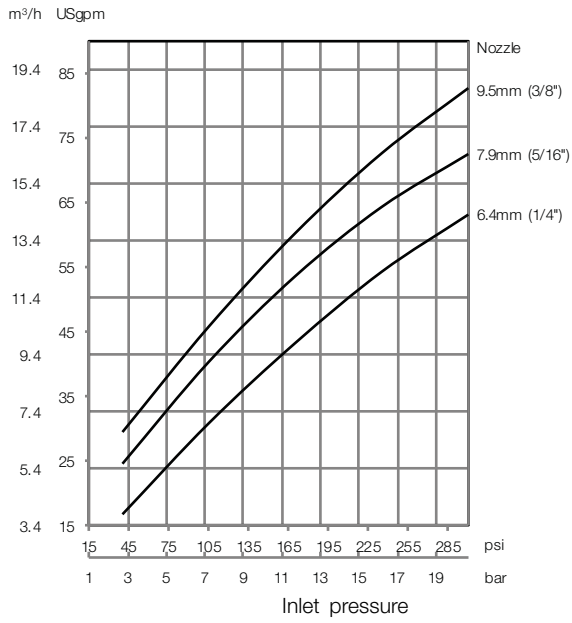

Flow Rate 4-nozzle

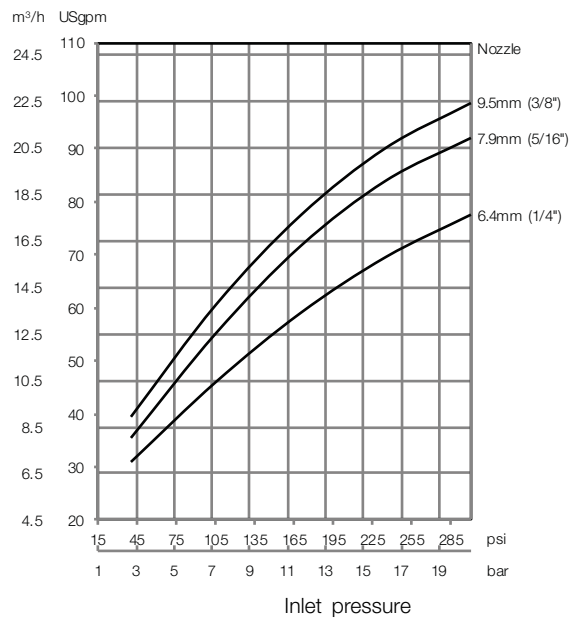

Impact 2-nozzle

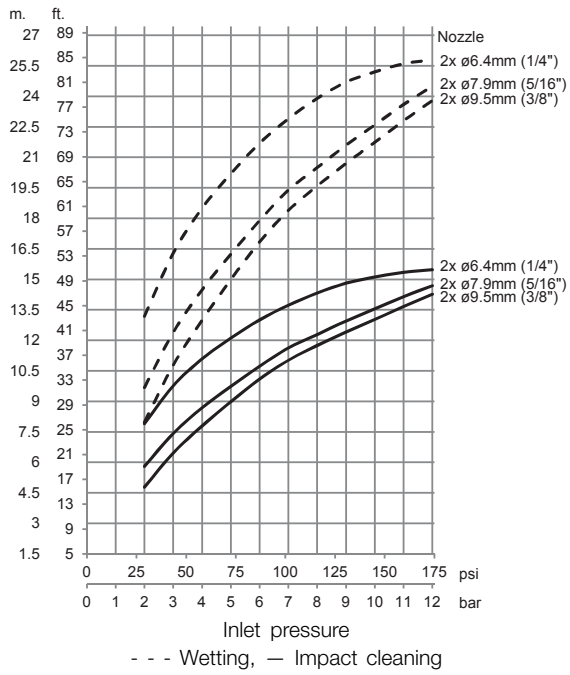

Impact 4-nozzle

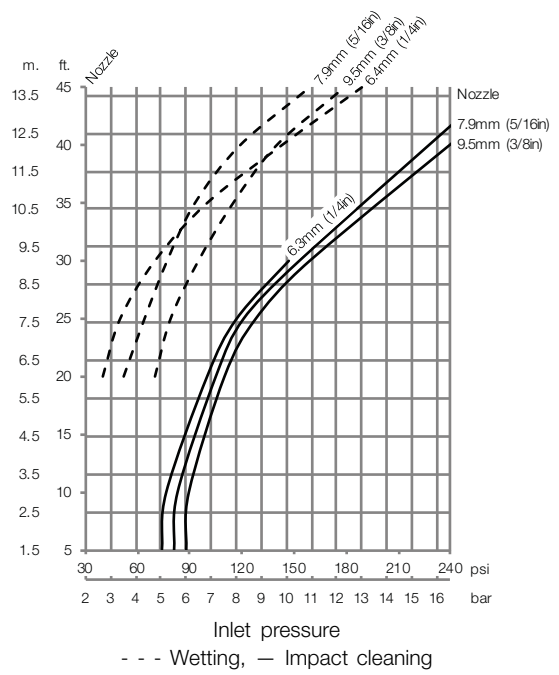

Custom inlets available. Contact your local Alfa Laval representative for details.

Cleaning Time

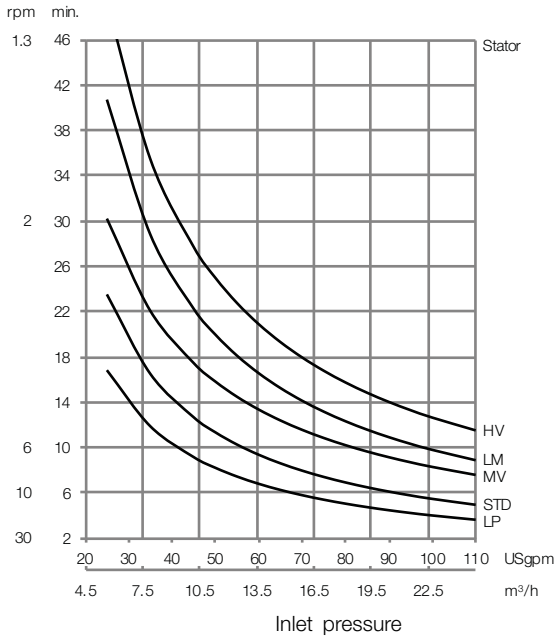

Dimensions 2-nozzle

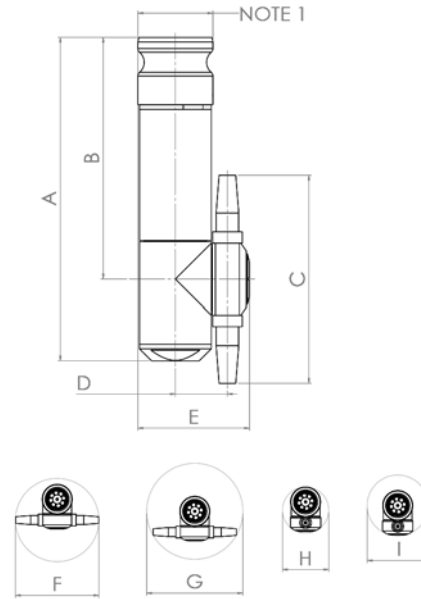

Dimensions 4-nozzle

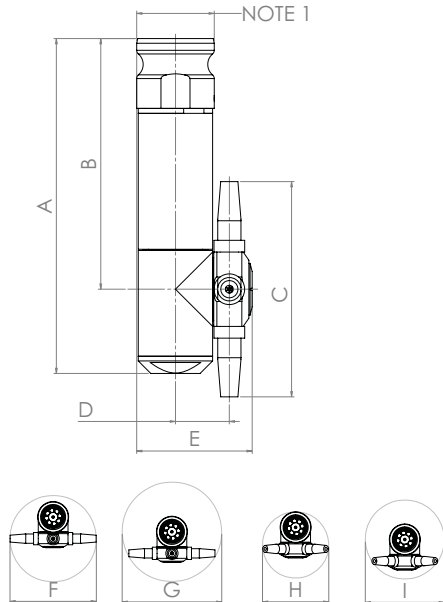

Dimensions low-profile

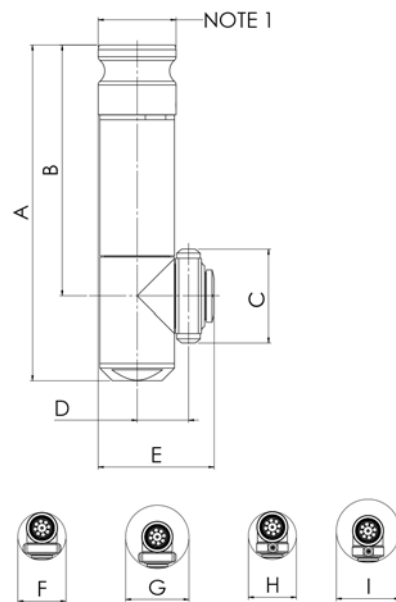

Dimensions 2-nozzle (mm)

A	B	C	D	E	F	G	H	I
272	204	175	44	94	176	202	98	129

NOTE 1: 1-1/2" FNPT/2" CAMLOCK OR 1-1/2" BSP/2" CAMLOCK (option shown above)

Dimensions 4-nozzle (mm)

A	B	C	D	E	F	G	H	I
272	204	175	44	94	176	202	134.47	160.35

NOTE 1: 1-1/2" FNPT/2" CAMLOCK OR 1-1/2" BSP/2" CAMLOCK (option shown above)

Dimensions low-profile version (mm)

A	B	C	D	E	F	G	H	I
272	204	76	42	94	97	129	97	129

NOTE 1: 1-1/2" FNPT/ 2" CAMLOCK OR 1-1/2" BSP/2" CAMLOCK (option shown above)

Standard Design

The choice of nozzle diameters can optimize jet impact length and flow rate at the desired pressure. As standard documentation, the Alfa Laval GJ PF can be supplied with a "Declaration of Conformity" for material specifications.

TRAX simulation tool

TRAX is a unique software that simulates how the Alfa Laval GJ PF performs in a specific tank or vessel. The simulation gives information on wetting intensity, pattern mesh width and cleaning jet velocity. This information is used to determine the best location of the tank cleaning device and the correct combination of flow, time, and pressure to implement.

A TRAX demo containing different cleaning simulations covering a variety of applications can be used as a reference and documentation for tank cleaning applications. The TRAX demo is free and available upon request.

Wetting Intensity

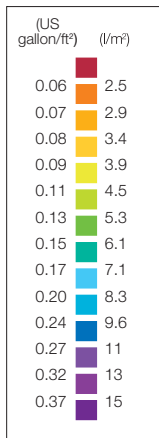

TD 523-206

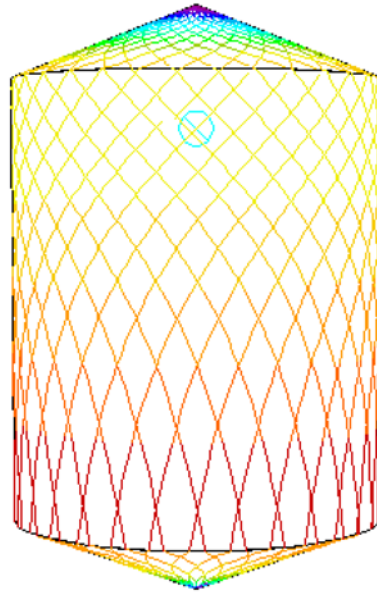

D9.1m, H14.7m, 2xØ7.94mm Time = 4.25 min.

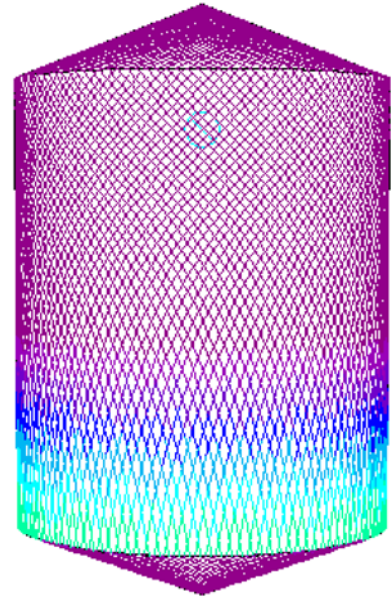

D9.1m, H14.7m, 2xØ7.94mm Time = 17 min.

Alfa Laval reserves the right to change specifications without prior notification.

How to contact Alfa Laval

Contact details for all countries are continually updated on our website. Please visit www.alfalaval.com to access the information direct.