



ThinkTop

V50 and V70



Instruction Manual

Lit. Code 200000549-5-EN-GB
Manual No. 100000340

Published by
Alfa Laval Kolding A/S
Albuen 31
DK-6000 Kolding, Denmark
+45 79 32 22 00

The original instructions are in English

© Alfa Laval Corporate AB 2020-10

This document and its contents are subject to copyrights and other intellectual property rights owned by Alfa Laval Corporate AB. No part of this document may be copied, re-produced or transmitted in any form or by any means, or for any purpose, without Alfa Laval Corporate AB's prior express written permission. Information and services provided in this document are made as a benefit and service to the user, and no representations or warranties are made about the accuracy or suitability of this information and these services for any purpose. All rights are reserved.

Contents

1	EC Declaration of Conformity.....	5
2	About ThinkTop.....	7
2.1	About this manual.....	7
3	Installation.....	9
3.1	Mechanical installation.....	10
3.2	Pneumatic installation.....	11
3.3	Electrical installation, Digital-IO 24V.....	12
3.4	Electrical installation, AS-interface.....	14
3.5	Electrical installation, IO-link.....	15
3.6	Option - Upper seat-lift surveillance.....	16
3.7	Option – Valve speed reduction.....	18
3.8	Option – Valve closing speed increase.....	19
4	Setup.....	21
4.1	Auto Setup.....	21
4.2	Flex Setup.....	22
4.3	Live Setup.....	24
4.4	Options.....	25
5	Troubleshooting.....	27
5.1	Calculating the error code.....	27
5.2	Error descriptions.....	28
5.3	Interpreting the error code patterns.....	31
5.4	Tips and Tricks.....	32

1 EC Declaration of Conformity

Revision of Declaration of Conformity 2019-05-01

The Designation Company

Alfa Laval Kolding A/S

Compagny Name

Albuen 31, DK-6000 Kolding, Denmark

Address

+45 79 32 22 00

Phone No

hereby declare that

Top Unit for Valve Control and Indication

Designation

ThinkTop V50, ThinkTop V70

Type

From serial number 0 to 10.000.000

is in conformity with the following directive with amendments:

- EMC Directive 2014/30/EU
- RoHS2 Directive 2011/65/EU

The person authorised to compile the technical file is the signer of this document

Global Product Quality Manager
Pump, Valves, Fittings and Tank Equipment

Title

Lars Kruse Andersen

Name

Kolding

Place

2019-05-01

Date

Signature



2 About ThinkTop

ThinkTop is a valve-top control unit that provides surveillance and control of valves during the fluid handling process. The control unit has been developed with user friendliness and robustness in mind.

ThinkTop comes with a valve control sensor board for connection to any PLC system. There are three types of communication interfaces available:

Digital I/O 24 VDC, AS-Interface v3.0, AS-I v2.11 and IO-link.

When the ThinkTop receives a signal from the PLC system to open the valve, a built-in solenoid valve shifts the connected valve into position. The position is detected through a sensor target attached to the valve stem through a touch-free sensor system. The position is then evaluated and if valid, the corresponding feedback is returned to the automation system via the communication interface.

V50 and V70 series

ThinkTop comes in two series: V50 and V70. The V50 series is the compact option with a feature set tailored to valves that require only one solenoid valve such as butterfly and single seat valves. The V70 series is the more flexible option that can be configured to meet the needs of the most demanding valve applications such as Mixproof valves.

2.1 About this manual

In this manual, you will find detailed descriptions of how to install and setup the different ThinkTop variants as well as detailed information about fault finding and maintenance. We recommend that you familiarize yourself with the content of the manual before you begin installation.

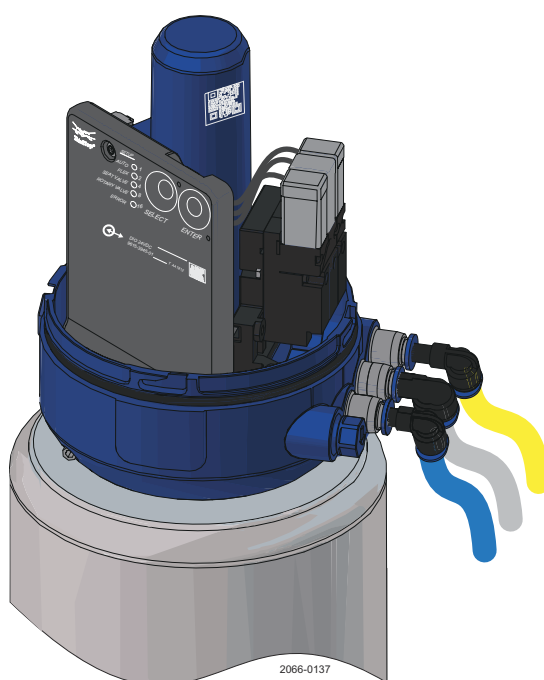

3 Installation

This chapter covers the installation of any ThinkTop variant within the V50 and V70 families on any Alfa Laval rising stem valve.

Tools

To carry out the installation, you need the following tools:

Hex key



◆ 2.5 mm

Adjustable spanner or flat wrenches

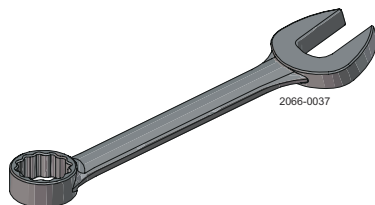

14, 19 mm

(additional 12, 15 and 17 for Seat lift sensor installation)

When using wire end ferrules for ease of electrical installation it is recommended to choose ferrules with a barrel length of 10mm to ensure full engagement in the terminals.

3.1 Mechanical installation

Mechanical installation is a two-step process, where you mount the sensor target to the actuator stem and the ThinkTop to the actuator top.

- 1 Fit the yellow sensor target to the actuator stem.

Tighten the sensor target by hand or use a 22 mm spanner (1...2 Nm)

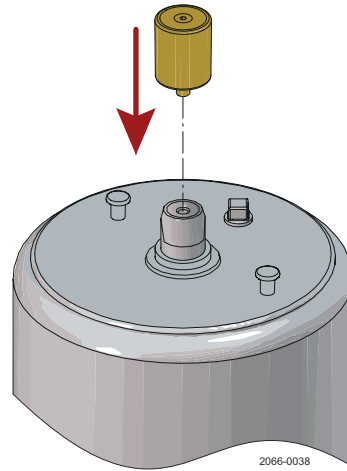

- 2 Mount the ThinkTop centred and flat against the actuator top.

Hold the ThinkTop flat and steady against the actuator top.

Use a 2.5 mm hex key to lightly tighten one of the two set screws.

Tighten the second set screw (1...1.5 Nm).

Tighten the first set screw (1...1.5 Nm).

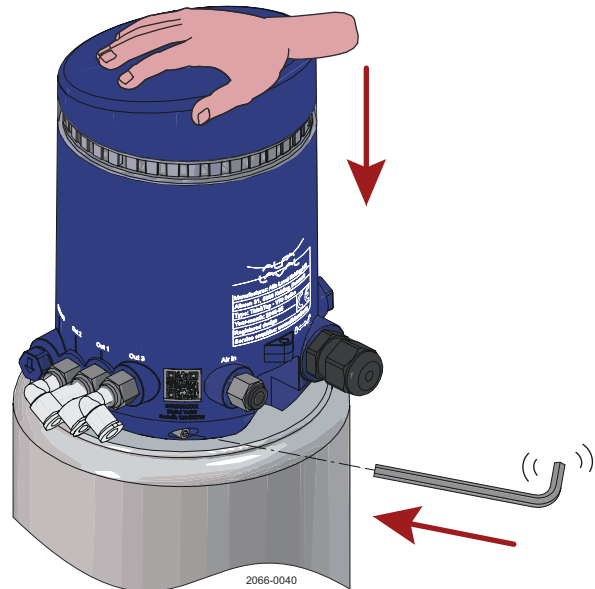

NOTE

While you can perform the mechanical installation of a seat lift sensor at this time, the electrical installation must be completed before you can test the seat lift sensor. For information on how to install and test the seat lift sensor, see [Install the seat lift sensor Option - Upper seat-lift surveillance](#) on page 16.

3.2 Pneumatic installation

Before you begin the pneumatic installation, cut the hoses to the preferred length.

- 1 Connect the air hoses between the air connectors on the ThinkTop and the air ports on the valve.

For double seat valves, ensure that the hoses run parallel to each other and do not overlap. This way, the hoses will be connected correctly.

Connect the air supply.

Connect the supply air hose to the Air in connector and turn on the supply air.

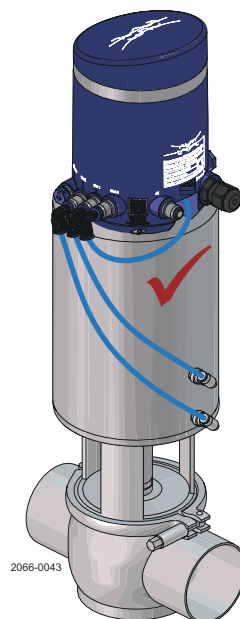

- 2 Verify that the air exhaust plug points downwards as indicated by the arrow to avoid water ingress in the pneumatic system. You can rotate the exhaust plug until it points in the right direction.

If the valve is placed horizontally so that the mushrooms are also horizontal, it is not possible to make the exhaust plug outlet point downwards. Instead, you can replace it with a downwards facing fitting.

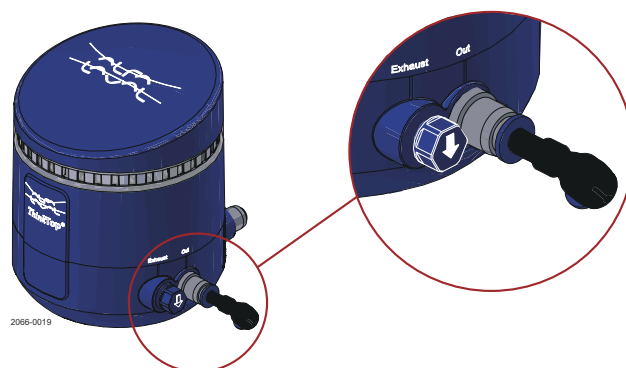

Indication colour and air connections

On the ThinkTop, the marking, numbering and colour coding of air hoses, air fittings, visual feedback, and electrical feedback follow the same pattern. This pattern ensures that Auto Setup functions properly.

The main valve function connects to the Out 1 air connector on the ThinkTop, which is keyed to the white/main feedback.

The upper seat-lift or auxiliary valve function connects to Out 2, which is keyed to the blue/Usl feedback.

The lower seat-push valve function connects to Out 3, which is keyed to the yellow/Lsp feedback.

The air connection numbers are printed on the cover of the control unit.

See the valve manual for information on the individual air ports on the valve.

On the V70 with 5/2 solenoid valve, port Out 1 is normally closed (NC) and port Out 2 is normally open (NO).

3.3 Electrical installation, Digital-IO 24V

1

- a) Remove the top cover by turning it counter clockwise and then lifting it upwards.
- b) Connect the cable to the ThinkTop, and then connect the wires to the terminals according to the wiring diagram.
- c) Tighten the cable gland using a 19 mm wrench (3 Nm).
Or tighten the M12 connector using a 14 mm wrench (0.6...1.5 Nm).
- d) Put the top cover back in place.
- e) Turn on the power supply.
If installed correctly, the light guide flashes green.

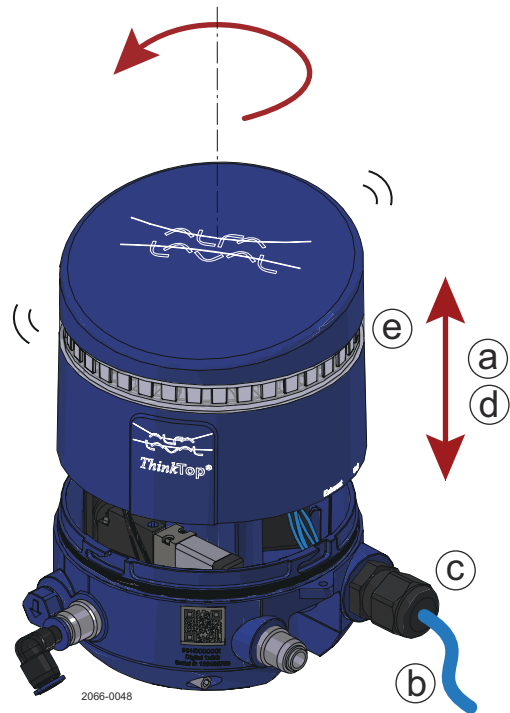

Wiring diagrams

Terminals V50 Digital-IO 24V			
1	Power supply	24V	(brown) (M12, pin 1)
2	Power supply	GND	(blue) (M12, pin 3)
3	out (PLC in)	Valve state	(white) (M12, pin 2)
4	out	Valve de-energised (DE-EN)	(black) (M12, pin 4)
5	out	Main valve energised (EN)	(grey) (M12, pin 5)
6	in	Solenoid valve 1 for main valve (SV1)	(pink) (M12, pin 6)

Terminals V70 Digital-IO 24V			
1	Power supply	24V	(brown) (M12, pin 1)
2	Power supply	GND	(blue) (M12, pin 3)
3	out	Valve state	(white) (M12, pin 2)
4	out	Valve de-energised (DE-EN)	(black) (M12, pin 4)
5	out	Main valve energised (EN)	(grey) (M12, pin 5)
6	out	Upper seat lift energised (USL)	(pink) (M12, pin 6)
7	out	Lower seat push energised (LSP)	(violet) (M12, pin 7)
8	in	Solenoid valve 1 for main valve (SV1)	(yellow) (M12, pin 8)
9	in	Solenoid valve 2 for USL (SV2)	(green) (M12, pin 9)
10	in	Solenoid valve 3 for LSP (SV3)	(red) (M12, pin 10)
1	Seat lift sensor	Supply	(brown)
2	Seat lift sensor	GND	(blue)
3	Seat lift sensor	Signal	(black)

3.4 Electrical installation, AS-interface

1

- a) Remove the top cover by turning it counter clockwise and then lifting it upwards.
- b) To allocate an address, use your preferred addressing device. See the device manual for more information.
- c) Connect the cable to the ThinkTop, and then connect the wires to the terminals according to the wiring diagram.
- d) Tighten the cable gland using a 19 mm wrench (3 Nm).
Or tighten the M12 connector using a 14 mm wrench (0.6...1.5 Nm).
- e) Put the top cover back in place.
- f) Turn on the power supply.
If installed correctly, the light guide flashes green.

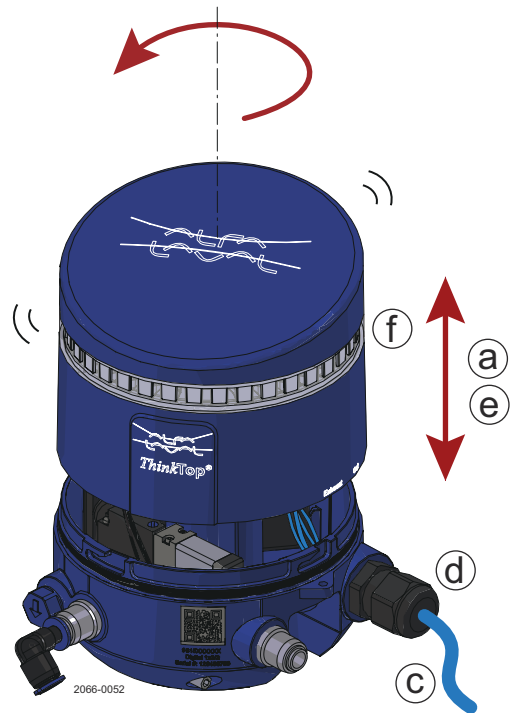

Wiring diagrams

Terminals V50 AS-interface			
1	AS-i supply	AS-i +	(brown) (M12, pin 1)
2	AS-i supply	AS-i -	(blue) (M12, pin 3)

Terminals V70 AS-interface			
1	AS-i supply	AS-i +	(brown) (M12, pin 1)
2	AS-i supply	AS-i -	(blue) (M12, pin 3)
1	Seat lift sensor	Supply	(brown)
2	Seat lift sensor	GND	(blue)
3	Seat lift sensor	Signal	(black)

3.5 Electrical installation, IO-link

- 1 a) Remove the top cover by turning it counter clockwise and then lifting it upwards.
- b) Fit the cable to the M12 connector and tighten it using a 14 mm wrench (0.6...1.5 Nm).
- c) Put the top cover back in place.
- d) Turn on the power supply.
If installed correctly, the light guide flashes green.

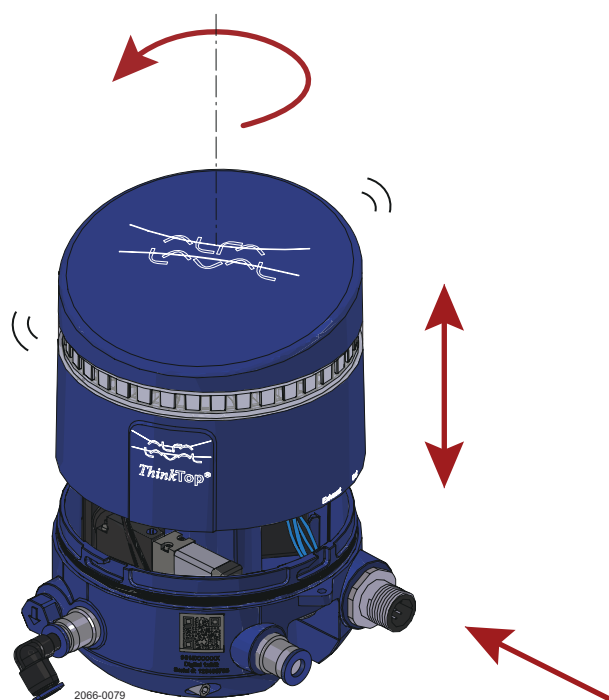

Wiring diagrams

Terminals V50 IO-Link			
1	Power supply	L+ 24V	(brown) (M12, pin 1)
2	Power supply	L- GND	(blue) (M12, pin 3)
3	Signal	IO-Link	(black) (M12, pin 4)

Terminals V70 IO-Link			
1	Power supply	L+ 24V	(brown) (M12, pin 1)
2	Power supply	L- GND	(blue) (M12, pin 3)
3	Signal	IO-Link	(black) (M12, pin 4)
1	Seat lift sensor	Supply	(brown)
2	Seat lift sensor	GND	(blue)
3	Seat lift sensor	Signal	(black)

3.6 Option - Upper seat-lift surveillance

This section is relevant for V70 variants where feedback for the upper seat lift function in a double seat valve application is required.

The parts referred to in this section are available as a seat lift sensor kit, art no. 9615414801.

If the valve at hand doesn't have the holes in the yoke an additional bracket kit is required. The bracket kit has art no. 9613095503 and its own installation instruction.

You will need an adjustable spanner or flat wrenches in the following sizes for this installation: 12, 14, 15 and 17 mm.

- 1 Remove the blue plug in the ThinkTop housing with a 14 mm flat wrench.

Fasten the seat lift sensor cable gland to the ThinkTop housing with at 15 mm flat wrench (1.5 Nm).

Fit the sensor cable in the cable gland.

Connect the wires to the seat lift sensor terminal according to the colour codes noted next to the terminals.

Fasten the cable gland nut with at 15 mm flat wrench (1.5 Nm).

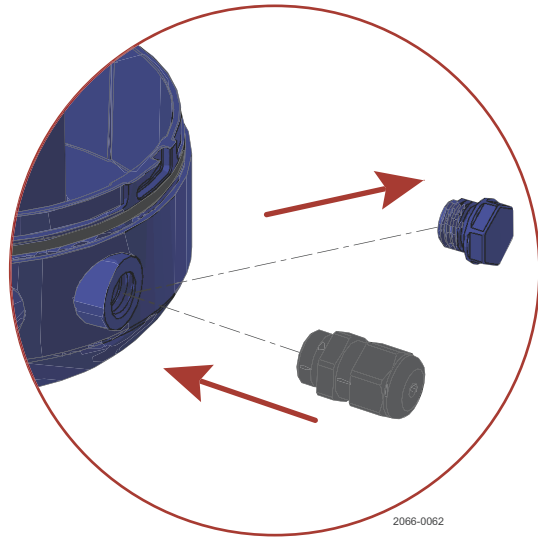

- 2 Fit the black bushing in the relevant hole in the valve yoke.

(The icons on the yoke refer to the shape of the valve plug.)

(The bushing will be fastened together with the sensor nut in step 7)

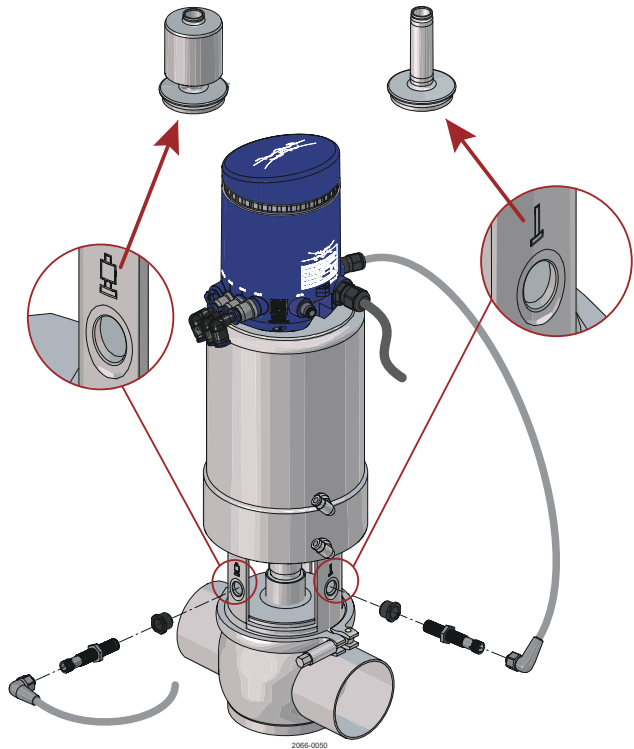

- 3 Position the valve so that the mechanical target is in front of the sensor by manually controlling solenoid valve two.

Fit a nut approximately half way into the thread on the sensor.

Fit the sensor in the bushing, so the tip of the sensor is approximately 1–2 mm from the mechanical target of the valve.

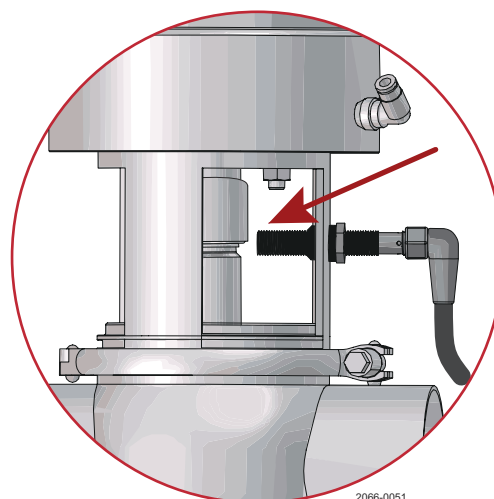

2066-0051

- 4 Fit the sensor cable on the sensor with the elbow pointing downwards.

Tighten the nut by hand on the sensor against the bushing for stability.

- 5 Turn on power.

- 6 Test the installation by energizing and deenergizing the upper seat lift function and verify that the LED on the seat lift sensor changes state.

Adjust the sensor position if necessary. The goal is to center the transition point between the always ON limit and the always OFF limit.

- 7 Fasten the sensor nut with a 17 mm flat wrench (1...2 Nm)

Fasten the sensor cable with a 14 mm flat wrench (0.6...1.5 Nm).

NOTE

Sensor centering advice:

- a) Closed seat position - Screw in the sensor until the local sensor LED comes ON.
- b) Open seat position - Unscrew the sensor while counting the rotations until OFF.
- c) Close the seat and screw the sensor approximately half the rotations back in and orient the cable plug downwards.

3.7 Option – Valve speed reduction

This section is relevant for valve applications where reduction of closing or opening speed is required. The one-way air throttle valves referred to in this section are available as art. no. 9611996114 for $\varnothing 6$ hoses and art. no. 9611996115 for $\varnothing 1/4$ " hoses.

A hex key is needed to remove the air fitting on the ThinkTop and an 8 mm spanner for tightening the special fitting.

(Hex key size: 4mm for the blue rim, $\varnothing 6$, fitting and 5mm for the grey rim, $\varnothing 1/4$ ", fitting)

- 1 The one-way air throttle valve controls the valve closing speed when mounted on the actuator (A), and controls the valve opening speed when it is mounted on the ThinkTop (B).

Mount the throttle valve on the actuator or ThinkTop using an 8 mm spanner and connect with air hose.

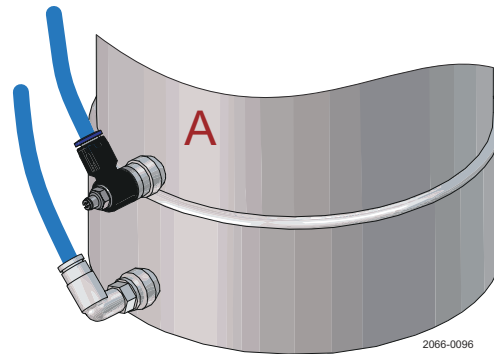

- 2 Adjust to the desired valve speed by turning the adjustment screw on the throttle valve.

Note: If the adjustment screw is fully tightened, valve speed is reduced to zero.

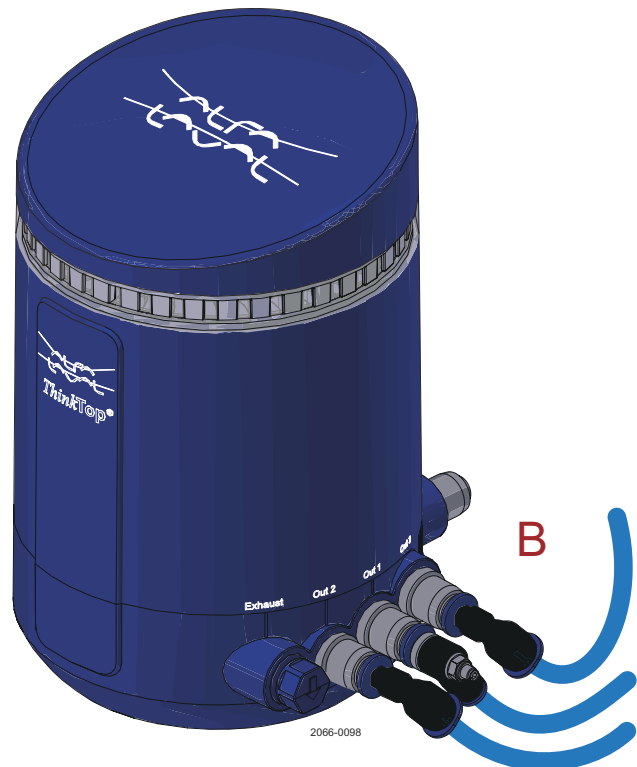

3.8 Option – Valve closing speed increase

This section is relevant for applications with large valves where increased closing speed is desired. The quick exhaust valve referred to in this section are available as art. no. 9611996116 for $\varnothing 6$ hoses.

- 1 Mount the quick exhaust valve on the desired actuator air connection and connect the air hose to the corresponding output on the ThinkTop.

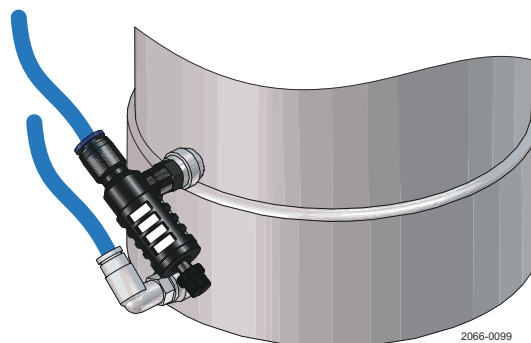

- 2 Adjust exhaust air flow with the adjustment screw. Then use the locking nut to secure the position of the adjustment screw.

Note: If the adjustment screw is fully tightened, the exhaust flow rate is zero.

4 Setup

When the ThinkTop has been installed correctly and is powered up for the first time, it flashes green. You can then begin the setup process.

Auto Setup works well for most applications, and we therefore recommend that you run Auto Setup before trying any of the other setup options.

4.1 Auto Setup

Auto Setup activates all relevant solenoid valves and automatically completes the setup.

Perform Auto Setup

- 1 Remove the top cover by turning it counter clockwise and then lifting it upwards.
- 2 Press the SELECT button and then the ENTER button to initiate the Auto Setup functionality.

When Auto Setup has completed successfully, the following happens:

- The light guide lights steady green.
- The control unit is now in operation mode, and the following features are activated:
 - Solenoid valve interlock
 - Surveillance mode
 - Logical signal adaption

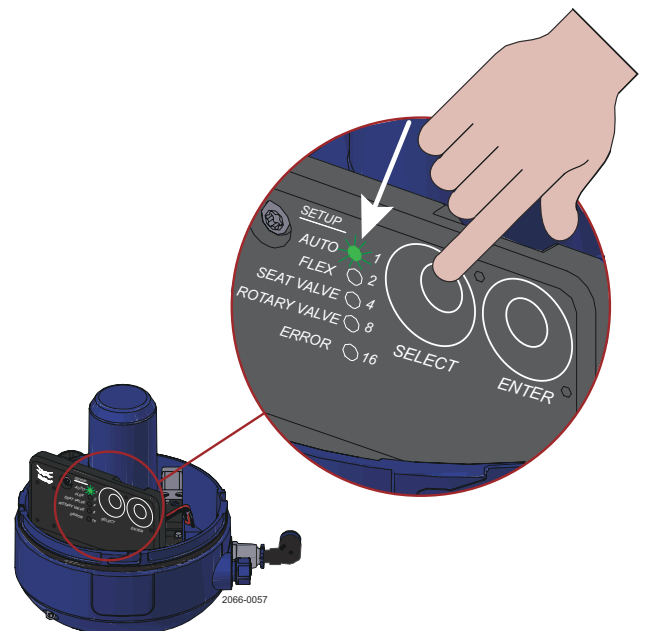

- 3 Put the top cover back in place.
- 4 Run an IO test to verify that the system returns the correct feedback.

Auto setup issues

- If Auto Setup returns an error, read the troubleshooting section for more information.
- If the IO test does not work as expected after completing Auto Setup, consider using Flex Setup.

Canceling Auto Setup

Press the SELECT button, to cancel Auto Setup.

4.2 Flex Setup

Flex Setup allows the setup of any rising stem valve and is a flexible alternative to Auto Setup. However, Flex Setup is not able to check for common installation mistakes. Flex Setup facilitates the detection and linking of valve functions and the related positions or sensor states to the outputs. Because it relies on additional operator input, the operator must be familiar with the content of the user manual.

Use Flex Setup in the following situations:

- When using a valve assembly that would prompt a fault during Auto Setup.
- When using external solenoid valves that the ThinkTop does not have direct control of.
- When adapting the ThinkTop to the closed / open valve position feedback paradigm.
- When setting up the specific valve type: All SSV (sizes) NO, shut off, maintainable. This valve type requires the rotary valve option. The valve would otherwise be detected as a seat valve by Auto Setup, which could lead to feedback issues on the main energized position.

The Flex Setup process varies depending on the ThinkTop and valve variants. The following describes a standard process:

- The process consists of a series of steps where each position of the valve is stored.
- Each step is keyed to specific visual feedback.
- A step must be skipped if a valve function does not provide a change in the sensor system relative to any of the other positions. To skip a step, press SELECT.
- The V50 has two setup steps and the V70 has four setup steps.
- All steps are generic and the labels that are used that relate to the Unique Mixproof valve are only placeholders.
- All steps are linked to a change of state of the seat lift sensor if no change of the main sensor system is detected.
- There is a 5 minute timeout in each setup. On timeout, the setup is cancelled, and no changes are saved.

The valve can be manually controlled conveniently via the solenoid valves.

You can operate the solenoid valves manually by turning the white manual override screw feature counter-clockwise.

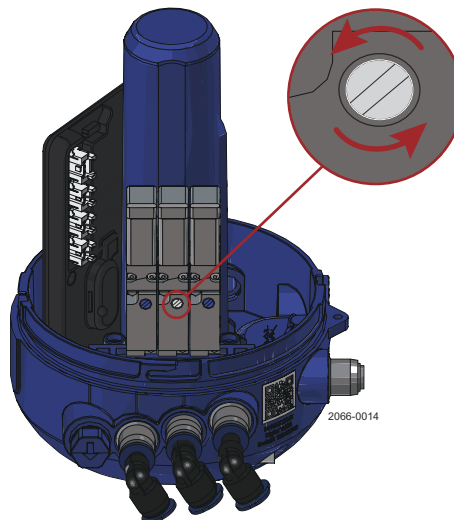

Perform Flex Setup

- 1 Remove the top cover by turning it counter clockwise and then lifting it upwards.
- 2 Press the SELECT button two or three times to navigate to either the Seat valve option or the Rotary valve option, then press ENTER.
- 3 Store the valve positions.

Green flashing [De-energized position]

Position the valve in de-energised position.

Press ENTER to store.

White flashing [Main energized position]

Position the valve in main energized position.

Press ENTER to store.

Blue flashing [Upper seat-lift position]

Position the valve in Usl energized position.

Press ENTER to store or SELECT to skip.

(E.g. Usl must be skipped if no seat-lift sensor is installed in a Mixproof valve application)

Yellow flashing [Lower seat-push position]

Position the valve in Lsp energized position.

Press ENTER to store or SELECT to skip.

When Flex Setup has completed:

- The light guide lights steady green.
- The control unit is in operation mode.

- 4 Put the top cover back in place.
- 5 Run an IO test to verify that the system returns the correct feedback.

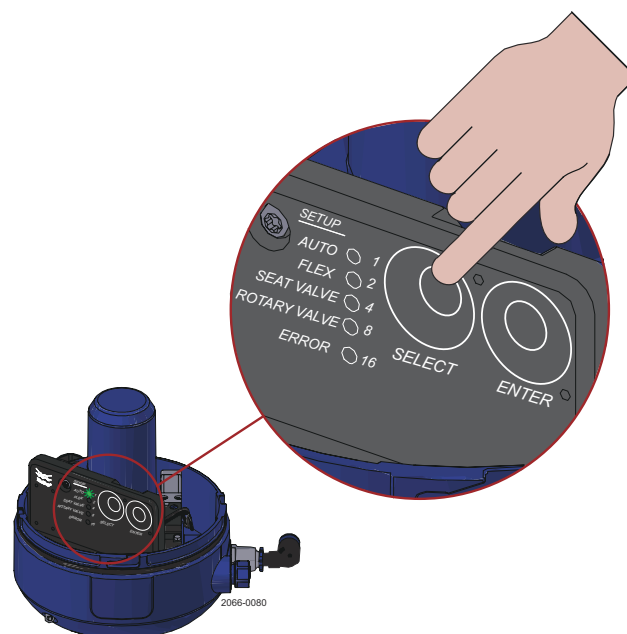

4.3 Live Setup

Live Setup is especially suited for live commissioning and live replacement. Unlike Auto Setup, Live Setup does not automatically activate the solenoid valves. It waits for all the detected solenoid valves to be energized by the PLC, and then saves the related positions detected by the sensor system. The light guide lights steady green when setup is completed.

Live Setup is active out of the box until one of the setup options has been completed.

Live commissioning

In applications where the mechanic, pneumatic and electrical installation has been completed, Live Setup can be carried out during regular IO test.



Live setup needs time to confirm each valve position, so if the inputs are manually toggled from the control room, make sure to wait for the respective position feedback from Live setup or wait for 30s between each toggle if feedback is not available.

Live replacement:

Use Live Setup, when you need to replace a control unit during the production process and must wait for the solenoid valves to be activated. Live Setup will complete the setup when all the solenoid valves have been activated at some point during the flow of the process.

During Live Setup, the feedback from the ThinkTop adapts to the registered position data from the initial movement of the valve.

Completed Live Setup

When Live Setup has completed successfully, the following happens:

- The light guide lights steady green.
- The control unit is in operation mode and the following features are activated:
 - Solenoid valve interlock
 - Surveillance mode
 - Logical signal adaption

4.4 Options

The operational functionality of the ThinkTop can be further customized with the following options.

Burst clean

If you want to enable the burst clean feature to optimize the cleaning process in a double seat valve application.

You can enable this option both before or after setup.

Navigate the menu until the LED 4 (Seat valve) flashes by pressing SELECT four times, and then press ENTER to toggle the option ON.

US bit mapping

If you want to optimize the electrical feedbacks for US applications which require PMO conformity.

You can enable this option both before or after setup.

Navigate the menu until the LED 8 (Rotary valve) flashes by pressing SELECT five times, and then press ENTER to toggle the option ON.

Key lock

If you want to tamper proof the control board, the SELECT button can be locked by holding the ENTER button for 7s until the 4 first LEDs has come ON.

Note: The SELECT button is unlocked by repeating the process.

Setup reset

Use the following process to reset the ThinkTop to factory default.

Hold both ENTER and SELECT for 7 seconds, until all LED's in the array are turned off.

The ThinkTop flashes green when reset.

Check setup status

Use the following procedure to check how the ThinkTop was setup.

Press ENTER. The setup status is presented on the LED array.

The LEDs indicate the type of setup that was used and the type of valve the control unit expects to be mounted on.

Note: The Live setup status is presented by LED 1 and 2 together.

5 Troubleshooting

The following table provides troubleshooting advice to resolve common issues that you might face when working with the ThinkTop.

5.1 Calculating the error code

You need the error code to use the troubleshooting table. To determine the error code, you add the numbers to the right of the active LED's.

Example: The following control board shows 1 + 4 + 16, which results in error code #21.

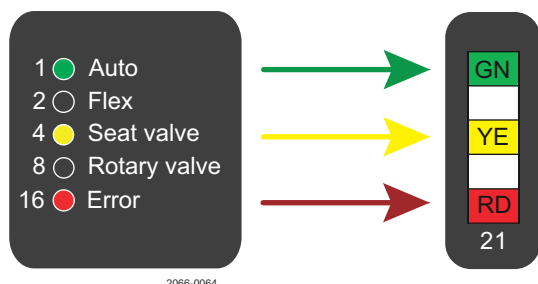

Alternatively, you can use the LED colour patterns to determine the error code. For more information, see [Interpreting the error code patterns](#) on page 31.

Check latest error

If you are trying to resolve a periodic error, and the error code is not displayed during troubleshooting, you can press the ENTER button twice to view the latest error code.

5.2 Error descriptions

#	Error description	Troubleshooting advice
15	Key lock active	The SELECT button is locked It can be unlocked by holding the ENTER button for 7s until the 4 first LEDs has come ON .
16	Sensor target missing	Verify that the sensor target is installed correctly.
17	Setup prerequisite issue Missing peripherals	The detected solenoid valves and/or seat lift sensor does not meet the Au- to Setup prerequisites. One or more solenoid valves might be missing. Verify that the solenoid valves are connected correctly to the control board. If the solenoid valves have been rearranged intentionally, then use Flex Setup to complete the setup.
18	Pneumatic part issue	The air hoses might cross or the cords from the solenoid valves might not be arranged correctly on the control board. - Verify that the installed air hoses run parallel to each other. - Verify that the SV cords are arranged: Out2-SV to socket 2, 1 to 1 and 3 to 3. If the air hoses or cords are intentionally arranged otherwise, then use Flex Setup to complete the setup.
19	Seat lift sensor issue	No change of state was detected from the seat lift sensor. Verify that the seat lift sensor installation is correct: - Test the installation by energizing and deenergizing the upper seat lift function and verify that the LED on the seat lift sensor changes state. - Check the wiring on the control board. - Check that the seat lift sensor is of the type IFT216 or a suitable alterna- tive.
20	Position not reached	During operation, the sensor target or the seat lift sensor did not reach the intended position on time. - Check the supply air. - Check the performance of the process valve actuator. - Check if stray air pressure is trapped within the central tube of the Think- Top by loosening the ThinkTop from the actuator. If so the actuator top seal needs to be serviced. Verify that the following prerequisites for Auto Setup are met: - The number of solenoid valves corresponds to the number of valve func- tions. - A solenoid valve is not locked in manual override. - Each valve function has a related sensor input available. - Use Flex Setup if these prerequisites cannot be met. If Flex Setup cancels with this error, it indicates that identical position data has been detected for two or more steps. - Retry Flex Setup. (Press SELECT to skip unnecessary steps.) - Verify that the seat lift sensor functions properly (if installed).

#	Error description	Troubleshooting advice
21	Unexpected process valve movement	<p>During operation the valve has moved away from the expected position.</p> <ul style="list-style-type: none"> - Check for manual override of solenoid valves. - Check the operation of the solenoid valves. If air ventilates from both exhaust and output simultaneously, the SV might be stuck in an intermediate position. - Check if stray air pressure is trapped within the central tube of the ThinkTop by loosening the ThinkTop from the actuator. If so the actuator top seal needs to be serviced. - If the duration of the error was very short it might be a pressure shock in the process valve. - If the ThinkTop is from 2020 or earlier and the valve at hand is of the specific type: 'SSV NO, shut off, maintainable' then do a new setup while using Flex setup and with the 'rotary valve' option. <p>If Auto Setup cancels with this error, a solenoid valve trigger input might be high.</p> <ul style="list-style-type: none"> - Reset all inputs and rerun Auto Setup.
22	Seat-lift sensor missing	<p>The seat-lift sensor is not detected.</p> <ul style="list-style-type: none"> - Check the seat-lift sensor cable and wiring. - Rerun setup if the seat-lift sensor has been intentionally removed.
23	Solenoid valve 1 missing	<p>Solenoid valve 1 is not detected.</p> <ul style="list-style-type: none"> - Check the solenoid valve wiring. - Rerun setup if the solenoid valve has been intentionally removed.
24	Solenoid valve 2 missing	<p>Solenoid valve 2 is not detected</p> <ul style="list-style-type: none"> - Check the solenoid valve wiring. - Rerun setup if the solenoid valve has been intentionally removed.
25	Solenoid valve 3 missing	<p>Solenoid valve 3 is not detected</p> <ul style="list-style-type: none"> - Check the solenoid valve wiring. - Rerun setup if the solenoid valve has been intentionally removed.
26	Interlock warning	<p>More than one solenoid valve trigger input is active.</p> <ul style="list-style-type: none"> - Reset the unnecessary solenoid valve input.
27	Output short circuit (Digital only)	<p>An output short circuit is detected.</p> <ul style="list-style-type: none"> - Check the wiring for the digital outputs.
28	Setup aborted	<p>Setup has been cancelled due to one of the following conditions: Timeout, SELECT was pressed, or fault condition was detected.</p> <ul style="list-style-type: none"> - If Flex setup is being attempted on a Mixproof application without the upper seat-lift sensor installed. Then the upper seat lift step needs to be skipped. This is done by pressing SELECT when blue is flashing. <p>No changes are saved when setup cancels.</p> <ul style="list-style-type: none"> - Rerun setup.
29	Blocked button	<p>A button is constantly pressed.</p> <ul style="list-style-type: none"> - Inspect the buttons. - If the buttons look OK, the control board needs to be replaced.

#	Error description	Troubleshooting advice
30	Voltage Low (Digital version only)	Too low supply voltage has been detected. - Verify that the voltage is above 21V.
30	Communication failure (IO-Link version only)	Communication with the IO-Link master is lost. The valve is returned to fail safe position. - Check the cable connection between the ThinkTop and the IO-Link master.
31	Safety stop	The sensor target has moved past the max. limit. The unit is locked in fail safe mode to protect the housing. - Verify that the actuator stroke length is compatible with the control unit. For example, the stroke length of the SSV long stroke valves is too long for the V50 housing. - Verify that the yellow sensor target that was supplied with the control unit is fitted correctly. The condition is reset on re-power.
32*	Pressure shock event (IO-Link version only)	Small unexpected valve movement events are counted and logged in the Diagnostic log. Definition: Movement between 0,2 - 0,4mm within 0,5s. * This event is not treated as an error. It will not affect the valve state feedback nor will it give a red visual feedback.

5.3 Interpreting the error code patterns

You can identify an error code by looking at the LED colour pattern.

The pattern is displayed in the following table:

1 ● Auto	2 ● Flex	4 ● Seat valve	8 ● Rotary valve	16 ● Error
----------	----------	----------------	------------------	------------

	GN		GN		GN		GN		GN		GN		GN		GN
		YE	YE			YE	YE			YE	YE			YE	YE
				YE	YE	YE	YE					YE	YE	YE	YE
								YE	YE	YE	YE	YE	YE	YE	YE
RD	RD	RD	RD	RD	RD	RD	RD	RD	RD	RD	RD	RD	RD	RD	RD
16	17	18	19	20	21	22	23	24	25	26	27	28	29	30	31

2066-0063

Example:

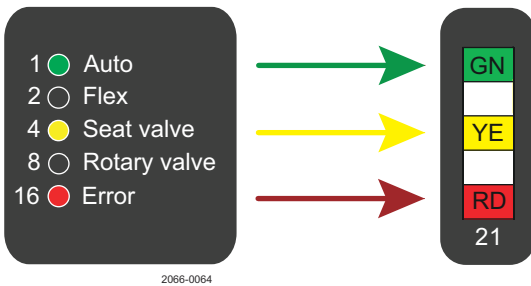

5.4 Tips and Tricks

Aligning feedbacks by rearranging solenoid valve plugs

For example, if you are setting up a ThinkTop with 2 solenoid valves on a double seat valve with only the lower seat lift function installed.

Due to the 2 SV ThinkTop comes with SV1 (main) and SV2 (USL) you will find that after you have done the setup that the actual lower seat position of the valve is keyed to the feedback labelled USL and the related blue colour.

The lower seat position can be aligned to the feedback labelled LSP by moving the solenoid valve 2 plug from header 2 to header 3, and then run Auto Setup.

Additionally, if you want the air hoses to also be parallel in this application then rearrange the solenoid valve plugs like this:

- SV1 plug to SV3 header (H3)
- SV2 plug to SV1 header (H1)
- Arrange the 2 air hoses parallel (Main valve will be connected to air Out2)
- Then run Auto Setup

Instruction video can be found on the ThinkTop product page.

