

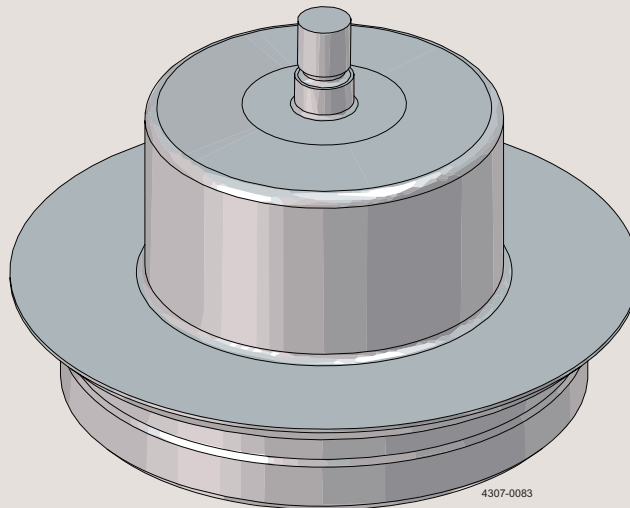

## Welding guidelines

Alfa Laval LeviMag®

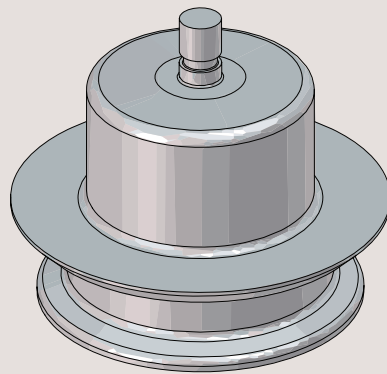

100001179-EN3

2020-02

Original manual



The information herein is correct at the time of issue but may be subject to change without prior notice

<b>1. Safety</b> .....	<b>4</b>
1.1. Important information .....	4
<b>2. Positioning of the weld plate</b> .....	<b>5</b>
2.1. Orientation .....	5
2.2. Mounting angle .....	6
2.3. Distance of the weld plate .....	7
2.4. Preparing the hole for the weld plate .....	8
<b>3. Welding guidelines</b> .....	<b>9</b>
3.1. Checklist before welding .....	9
3.2. Tack welding (inside tank) .....	10
3.3. Tack welding and final welding .....	11
<b>4. Weld plate verification</b> .....	<b>14</b>
4.1. Inside the tank .....	14
4.2. Outside the tank .....	15
<b>5. Checklist</b> .....	<b>16</b>
5.1. Before welding .....	16
5.2. During welding .....	16
5.3. After welding .....	16
<b>6. Pressure rating</b> .....	<b>17</b>
6.1. Specification of pressure weld plates according to PED 2014/68/EU .....	17
6.2. Specification of pressure weld plates according to ASME VIII div. 1 .....	17
<b>7. Part list</b> .....	<b>18</b>
7.1. Accessories .....	18

# 1 Safety

The Alfa Laval LeviMag® weld plate is an integrated part of the tank.

This guide provides general installation guidelines for the weld plate.

Before starting to weld make sure that you have received all necessary material certificates and approvals which are needed.

## 1.1 Important information

---

Incorrect installation, mounting and use, removal of security elements, lack of inspections and maintenance and improper connections may cause severe personal injury or property damage. Therefore, it is important that the mixer is being transported, handled, installed, started, controlled, serviced and repaired correctly exclusively by qualified personnel.

The weld plate is an integrated part of the tank and the tank can also be a pressure-device. In such case the weld plate must be approved and comply with the valid pressure tank code.

The most common faults which occur when welding weld plates into tanks are deformations introduced during the welding process – therefore, it is important to follow the guidelines, recommendations and descriptions in this document - how to weld the weld plate into the tank.

Other welding around and near the weld plate position must be completed before cutting the final hole for the weld plate.

The following safety terminology is used to indicate the hazard level:

### **WARNING**

Indicates that special procedures must be followed to avoid serious personal injury.

### **CAUTION**

Indicates that special procedures must be followed to avoid damage to the mixer.

### **NOTE**

Indicates important information to simplify or clarify procedures.

---

## 2 Positioning of the weld plate

*Pay special attention to the instructions below so that severe personal injury and/or damage to the weld plate and LeviMag® is avoided.*

*Always read this manual thoroughly.*

Complete all other welding (e.g. tank outer valves, sensor adapter connections, sample ports, etc.) before cutting the final hole for the weld plate.

### CAUTION

All other (already done and finalized) welding near the final hole for the weld plate may warp the weld plate when it is being welded in.

Before cutting the hole in the tank for the weld plate, ensure that information in 2.1 Orientation, 2.2 Mounting angle, 2.3 Distance of the weld plate and 2.4 Preparing the hole for the weld plate is followed.

### 2.1 Orientation

Ensure before welding the weld plate that the bolt-hole pattern on weld plate WP81 is positioned where the drive unit and motor can be mounted and dismantled without interfering with tank legs or other obstructions.

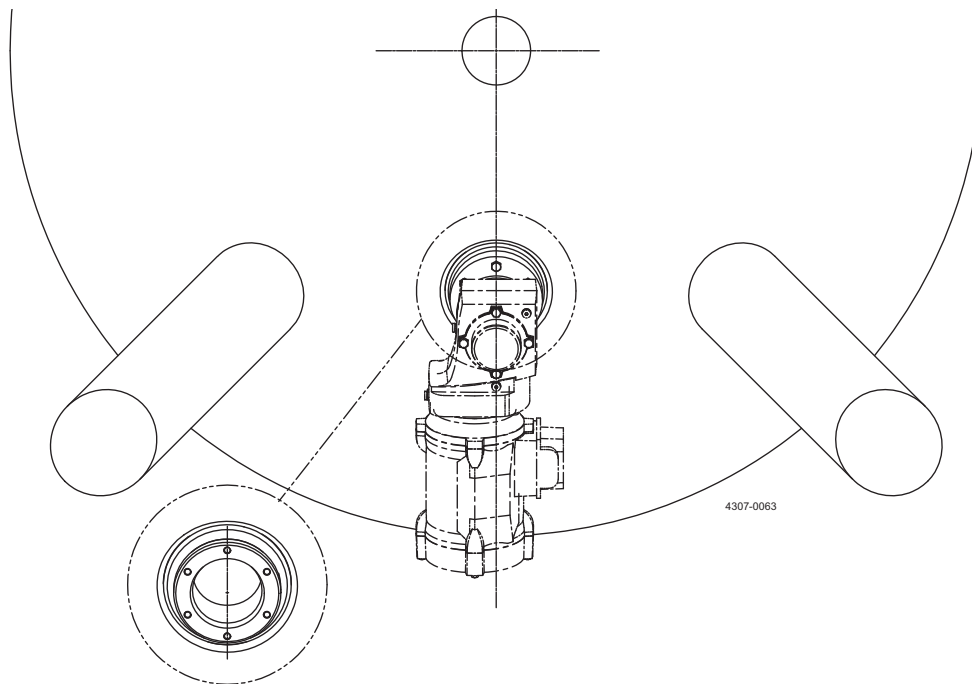

## 2 Positioning of the weld plate

Pay special attention to the instructions below so that severe personal injury and/or damage to the weld plate and LeviMag® is avoided.

Always read this manual thoroughly.

### 2.2 Mounting angle

The gear motors are filled with oil that enables them to be mounted as described below – please ensure that the position of the weld plate lives up to the requirements below.

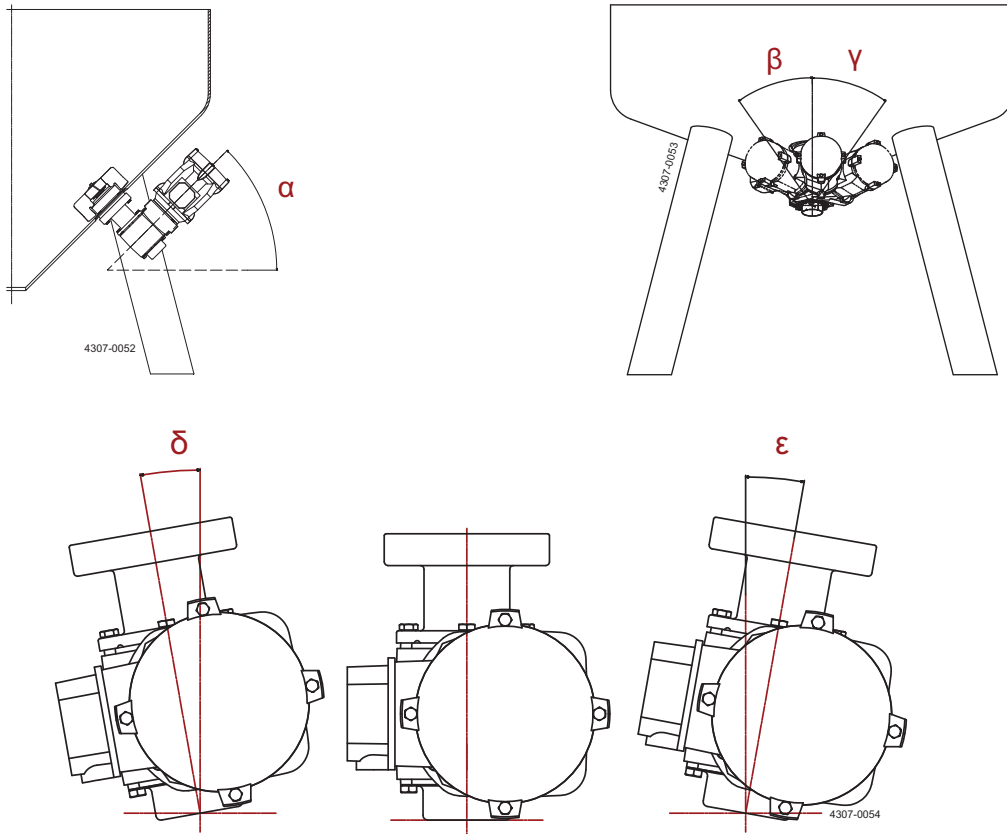

The gear motor can be selected in different configurations - and regarding mounting angles in two different configurations for  $\alpha$ .

The gear motor should be mounted with motor pointing upwards ( $\beta = 0$  and  $\gamma = 0$ ).

If the gear motor has to be positioned slightly to the right or left ( $\beta \neq 0$  or  $\gamma \neq 0$ ) to avoid interference with tank legs or other obstructions, angle  $\alpha$  together with  $\beta$  or  $\gamma$  will result in that the gear motor are rotated slightly to the right ( $\epsilon$ ) or to the left ( $\delta$ ).

The allowable angles for  $\epsilon$  and  $\delta$  are:

Designation	Angle	
$\alpha$	0°-22°	23°-45°
$\delta$	max. 5°	max. 5°
$\epsilon$	max. 5°	max. 5°

## 2 Positioning of the weld plate

Pay special attention to the instructions below so that severe personal injury and/or damage to the weld plate and LeviMag® is avoided.

Always read this manual thoroughly.

### 2.3 Distance of the weld plate

Consider the diameter of the weld plate and make sure it does not conflict with other equipment in the tank, e.g. outlet valve.

If low level mixing is important, place the mixer as close to center as possible.

Follow below guidelines for positioning the weld plate in the tank.

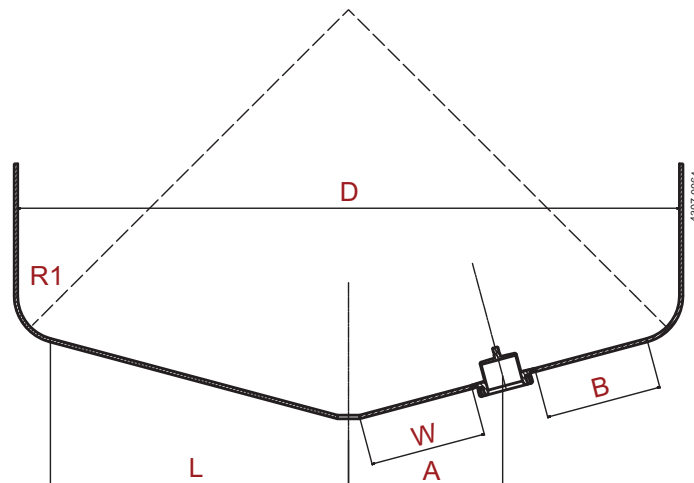

Description	Note
Distance from center to weld plate, max.	$A = 0.35 \times D$
Distance from center to weld plate, min.	$A^*$
Tank diameter	$D$
Length from R1 to center	$L$
Knuckle radius	$R1$
Length from the weld seam of the weld plate and to any other weld seam	$W^* = 5 \text{ mm}$

\*Also ensure that the distance W and B are according to the relevant pressure regulation for the tank and ensure that there are no obstructions for the impeller size inside the tank.

## 2 Positioning of the weld plate

Pay special attention to the instructions below so that severe personal injury and/or damage to the weld plate and LeviMag® is avoided.

Always read this manual thoroughly.

### 2.4 Preparing the hole for the weld plate

#### Step 1

Make sure that all other needed welding on the bottom of the tank is completed before marking the hole for the weld plate.

#### Step 2

Make the hole in the tank using cutting tools that does not create too much heat (e.g. hole saw / hole cutter) to the tank bottom and with a diameter as below:

Weld plate size	Weld plate diameter (mm)	Hole diameter (mm), D
WP50	Ø90	Ø90,7 ± 0,5
WP81	Ø149	Ø149,7 ± 0,5

#### Step 3

Chamfer the outwards edges by 45°, leaving a 1-2 mm recess towards the inside of the tank.

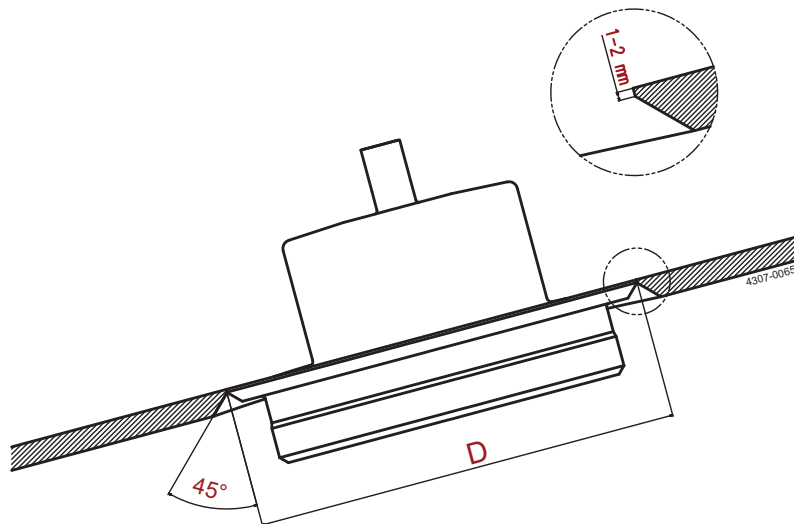



### 3.1 Checklist before welding

---

Ensure the following before welding (also see 5 Checklist):

1. All threads in weld plate are not damaged - check with screws.
2. The heat number on the weld plate is matching.
  - a. Material certificate for the weld plate.
  - b. Tank manufacturing drawing.
  - c. Material certificate according to the local pressure code.
3. Remove possible other detachable components on the weld plate such as the bearing part and screws.

#### **NOTE**

Be careful – do not overheat the material during all welding operations!

---

### 3 Welding guidelines

---

#### 3.2 Tack welding (inside tank)

---

##### Step 1

Position the weld plate in the hole. Ensure that it is completely aligned and flush with the inside surface of the tank.

---

##### Step 2

Tack weld the weld plate at two diametrical locations A and B, from inside of the tank, using a filler.

##### NOTE

The filler type must correspond to the material specification of the weld plate and the tank.

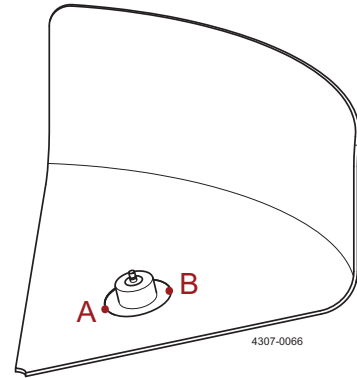

##### Step 3

Again - ensure that the weld plate is aligned with the inside surface of the tank wall.

---

##### Step 4

Tack weld the weld plate on two more places, C and D from inside of the vessel wall.

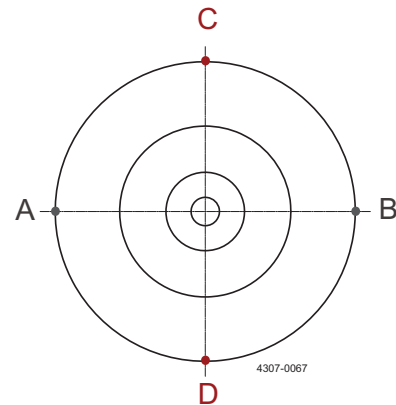

#### 3.3 Tack welding and final welding

##### CAUTION

Incorrect welding procedures may deform and warp the weld plate – therefore all the following steps must be done with a heat sink tool (see 7 Part list) on the weld plate and cooling down time between each welding step.

##### Step 1

Mount the heat sink on the weld plate and tighten the screw until the heat sink fits tight (appr. 5-10Nm) – do not overtighten.

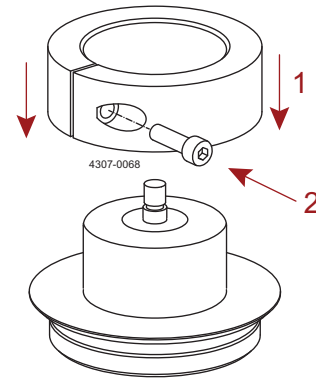

##### Step 2

Tack weld the weld plate on four more points.

Start at point 1 and diagonally point 2 then point 3 and at last diagonally point 4, all from outside of the tank wall.

Ensure the weld zone is cooled down with compressed air between each point.

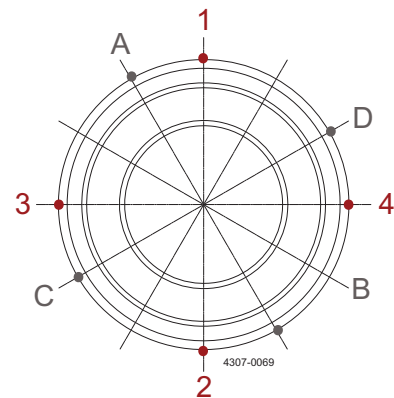

##### Step 3

Tack weld the weld plate on four more points.

Start at point 5 and diagonally point 6 then point 7 and at last diagonally point 8, all from outside of the tank wall.

Ensure the weld zone is cooled down with compressed air between each point.

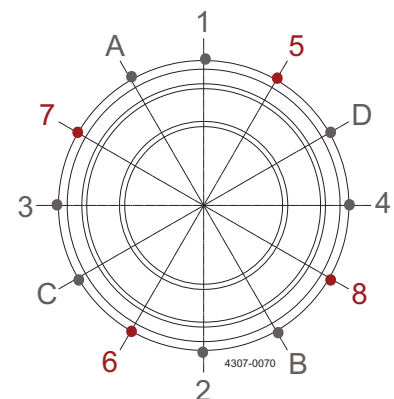

### 3 Welding guidelines

---

#### Step 4

From outside the tank:

Weld from tack A to 1 – cool down with compressed air.

Weld from tack B to 2 – cool down with compressed air.

Weld from tack C to 3 – cool down with compressed air.

Weld from tack D to 4 – cool down with compressed air.

Ensure that the welded sections are cooled down with compressed air after each welding.

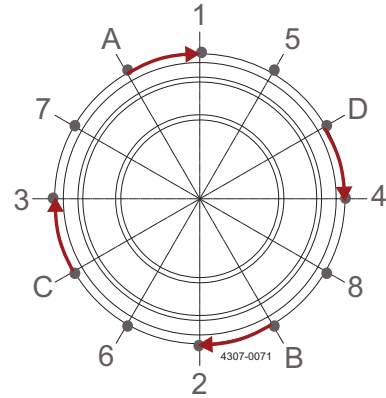

#### Step 5

From outside the tank:

Weld from tack 1 to 5 – cool down with compressed air.

Weld from tack 2 to 6 – cool down with compressed air.

Weld from tack 3 to 7 – cool down with compressed air.

Weld from tack 4 to 8 – cool down with compressed air.

Ensure that the welded sections are cooled down with compressed air after each welding.

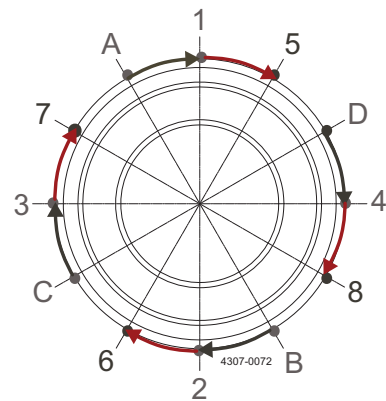

#### Step 6

From outside the tank:

Weld from tack 5 to D – cool down with compressed air.

Weld from tack 6 to C – cool down with compressed air.

Weld from tack 7 to A – cool down with compressed air.

Weld from tack 8 to B – cool down with compressed air.

Ensure that the welded sections are cooled down with compressed air after each welding.

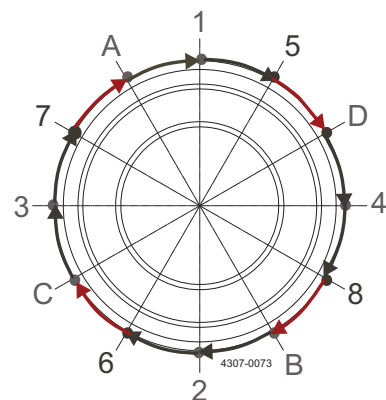

**Step 7**

Repeat step 4 to 6 from inside the tank.

Ensure that the welded sections are cooled down with compressed air after each welding.

---

**Step 8**

Once the welding is complete, allow the weld plate to cool completely.

Remove the heat sink tool.

---

**Step 9**

During grinding and polishing, allow cooling time between each process.

**CAUTION**

Grinding not allowed inside diameter  $\emptyset$  – only light polishing.

Size	Diameter $\emptyset$
WP50	22 mm
WP81	39 mm

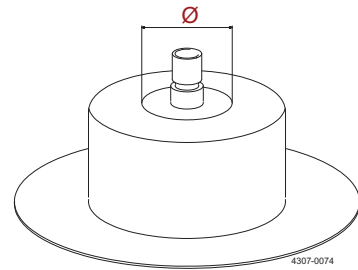
**Step 10****NOTE**

It is important that the weld plate does not reach high temperatures – take your time. Do not quench with water. Weld plate may warp due to shrinking.

---

## 4 Weld plate verification

---

Check the weld plate for deformations by using the inspection tools (see 7 Part list).

### Incorrect installed weld plates

If the weld plate was exposed to excessive heat during the welding, grinding, polishing or if the requirement in 3 Welding guidelines has not been followed there is a high risk that the weld plate is deformed.

If the inspection tools are touching the weld plate walls during the test the weld plate must be replaced as it will affect the mixer performance and possibly damage the mixer components.

### 4.1 Inside the tank

---

#### Step 1

Mount the inspection tool on the weld plate.

#### NOTE

The inspection tool can be used for both weld plate size WP50 and WP81.

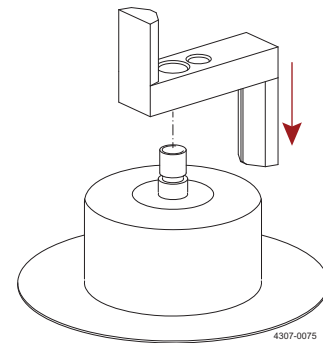

#### Step 2

While pressing downwards, ensuring that the tool rotates on the flat surface  $\varnothing$  seen in Step 9 in chapter 3.3 Tack welding and final welding, rotate the inspection tool and ensure that it can rotate smoothly all around without touching the weld plate.

#### NOTE

Do not use upper part as handle while rotating.

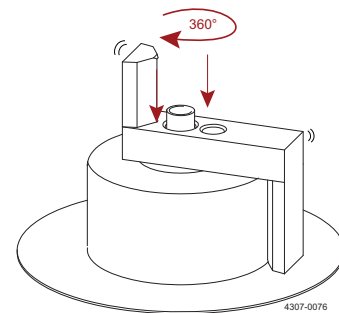

## 4 Weld plate verification

### 4.2 Outside the tank

#### Step 1

Adjust the tool to the weld plate size.

Place the stop ring (1) on the correct weld plate size on the shaft and mount the screw (2).

Mount the rotating head (3) on the shaft according to the weld plate size.

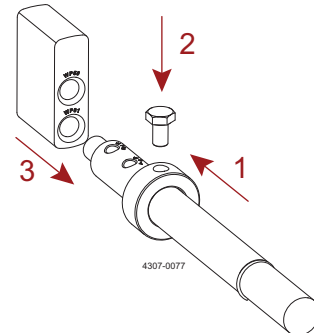

#### Step 2

##### Option WP50

Place the inspection tool into the weld plate size 50 (1) and fastening the tool with the two screws (2).

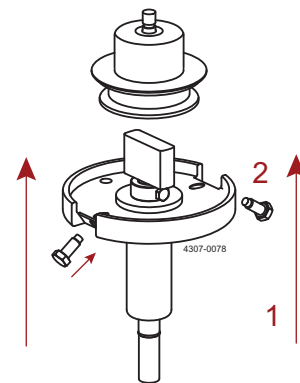

##### Option WP81

Place the inspection tool into the weld plate size 81 (1) and fastening the tool with the two screws (2).

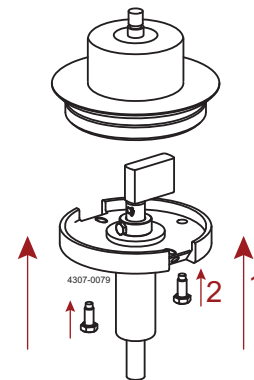

#### Step 3

Ensure that the shaft on the inspection tool rotates smoothly without touching the weld plate.

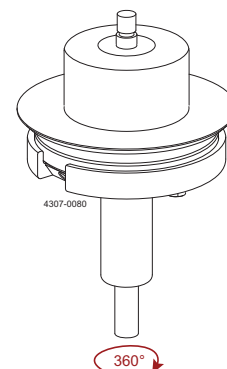

## 5 Checklist

To ensure correct installation, before using the LeviMag®, make sure to complete each step in the checklists below.

### 5.1 Before welding

Make sure all steps are checked before welding.

Step	Description	Checked
1	Verify: heat number on the weld plate matches the material certificate.	<input type="checkbox"/>
2	Verify: item number of the weld plate matches the item number reference on the tank manufacturing drawing.	<input type="checkbox"/>
3	Carefully read and understand the Welding guidelines for LeviMag® weld plate.	<input type="checkbox"/>
4	Ensure that the welder is authorized and familiar with this type of welding operation.	<input type="checkbox"/>
5	Ensure that the weld plate is positioned to allow mounting and removal of the drive unit.	<input type="checkbox"/>
6	Cut the hole for the weld plate and ensure proper placement.	<input type="checkbox"/>

### 5.2 During welding

Make sure all steps are checked during welding.

Step	Description	Checked
1	Tack weld the weld plate from inside the tank.	<input type="checkbox"/>
2	Use heat sink tool during the welding process (strongly recommended).	<input type="checkbox"/>
3	Tack weld the weld plate from outside the tank.	<input type="checkbox"/>
4	Weld the weld plate from outside the tank.	<input type="checkbox"/>
5	Weld the weld plate from inside the tank.	<input type="checkbox"/>
6	Remove the heat sink.	<input type="checkbox"/>

### 5.3 After welding

Make sure all steps are checked after welding.

Step	Description	Checked
1	Check threads for deformations (WP81).	<input type="checkbox"/>
2	Check weld plate for deformations using inspection tools.	<input type="checkbox"/>
3	Grind and polish the welds manually.	<input type="checkbox"/>
4	Check weld plate for deformations using inspection tools.	<input type="checkbox"/>
5	Inspect the tank for scratches, marks and damage.	<input type="checkbox"/>



Pay special attention to the instructions below so that severe personal injury and/or damage to the weld plate and mixer is avoided.

Always read this manual thoroughly.

---

### 6.1 Specification of pressure weld plates according to PED 2014/68/EU

---

Specification for weld plate WP50 and WP81:

#### Design Data

Corrosion allowance:	0 mm
Material:	1.4404 EN 10028-7 and EN 13445 or 1.4404 EN 10222-5
Design temperature:	150°C
Minimum design metal temperature:	0°C
Max. allowable working pressure:	FV+ 0.7MPa (7bar)
Design pressure, internal:	0.7MPa (7bar)
Design pressure, external:	0.1MPa (1bar)

The design is made according to EN 13445-3 and fulfils the requirements of PED 2014/68/EU.

Weld plates do not have a component certificate, but material certificate and pressure calculations can be supplied.

---

### 6.2 Specification of pressure weld plates according to ASME VIII div. 1

---

Specification for weld plate WP50 and WP81:

#### Design Data

Service:	Non-toxic
Corrosion allowance:	0"
Material:	Type 316L
Design temperature:	150°C
Minimum design metal temperature:	0°C
Max. allowable working pressure:	FV+ 0.7MPa (7bar / 101.5psi)
Design pressure, internal:	0.7 MPa (7 bar/101.5psi)
Design pressure, external:	0.1 MPa (1bar/14.5psi)

Design is made according to ASME VIII div. 1 and fulfils the requirements of the ASME standards.

Weld plates do not come with a U2 certificate, but material certificate and pressure calculations can be supplied.

---

# 7 Part list

Accessories

## 7.1 Accessories

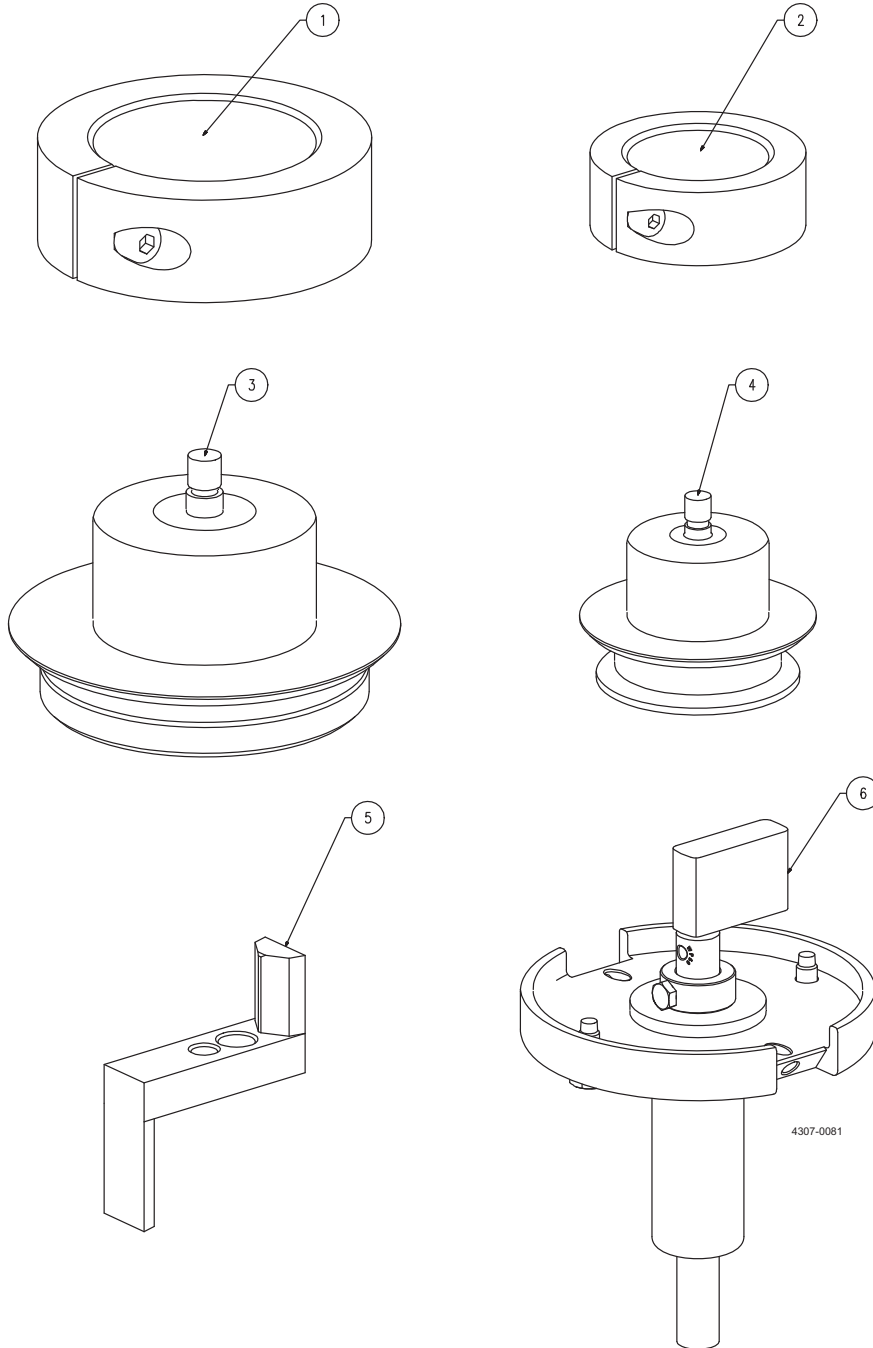

---

*Accessories*

---

---

<b>Pos</b>	<b>Qty</b>	<b>Denomination</b>	<b>Item</b>
1	1	Heat sink WP81, external .....	9615460801
2	1	Heat sink WP50, external .....	9615460201
3	1	Weld Plate WP81 .....	9615433701
4	1	Weld Plate WP50 .....	9615454401
5	1	Inspection tool, external .....	9615468201
6	1	Inspection tool, internal .....	9615475901

---

**How to contact Alfa Laval**

Contact details for all countries are continually updated on our website.

Please visit [www.alfalaval.com](http://www.alfalaval.com) to access the information directly.

© Alfa Laval Corporate AB

This document and its contents is owned by Alfa Laval Corporate AB and protected by laws governing intellectual property and thereto related rights. It is the responsibility of the user of this document to comply with all applicable intellectual property laws. Without limiting any rights related to this document, no part of this document may be copied, reproduced or transmitted in any form or by any means (electronic, mechanical, photocopying, recording, or otherwise), or for any purpose, without the expressed permission of Alfa Laval Corporate AB. Alfa Laval Corporate AB will enforce its rights related to this document to the fullest extent of the law, including the seeking of criminal prosecution.