



Alfa Laval IM 20 Rotary Jet Mixer

Superior mixing – Liquid, Gas and Powder

The patented IM 20 Rotary Jet Mixer (RJM) does not only mix fast, efficient and uniform but creates also the necessary process flexibility that makes it easy to switch to new product formulations with diverse viscosities, densities and volumes. Besides classic liquid to liquid mixing the RJM is excellent for gas and powder dispersion plus a superb tank cleaning machine.

Applications

Process and storage vessels between 5-200 m³ used in a wide range of industries such as: beer & beverage, food & ingredients, home & personal care, health care, biotech and chemical industry etc.

Operation

Secure that the mixer is positioned in the correct level and submerged into the liquid before round pumping or when adding any additional products from any up-stream pipe works.



TECHNICAL DATA

Lubricant: Self-lubricating with the mixing/cleaning fluid
 Connection: Standard thread 2" BSP or NPT, female
 Min. tank opening: See dimension drawings

Pressure

Working pressure: 2-12 bar
 Recommended pressure during mixing: 2-6 bar
 Recommended pressure during CIP: 5-6.5 bar



PHYSICAL DATA

Materials

Materials: AISI 316L, AISI 316, SAF 2205, PEEK, PVDF, Tefzel, Ceramics

Weight: 12.2 kg

Temperature

Max. working temperature: 95°C
 Max. ambient temperature: 140°C

Benefits

Using the IM 20 Rotary Jet Mixer makes it possible, at a modest investment, to perform fast and efficient mixing in a hygienic system. In traditional systems, using propeller mixers, a rotating shaft penetrates the tank wall, and a mechanical seal and a gear box are installed. With the Rotary Jet Mixer technology the shaft, seal and gearbox are eliminated, and a more hygienic design is obtained. With the Rotary Jet Mixing technology good mixing is achieved without the use of baffles. The Rotary Jet Mixer can also be used for gas dispersion and for dispersion and dissolving of powder. The IM 20 can furthermore be used for efficient CIP when the tank is empty, saving liquid, chemicals and energy compared to a fixed spray ball CIP system.

Flow rate

Relationship between inlet pressure and flow rate for liquids with waterlike properties for the IM 20 Rotary Jet Mixer.

Volumetric flow rate [m³/h]

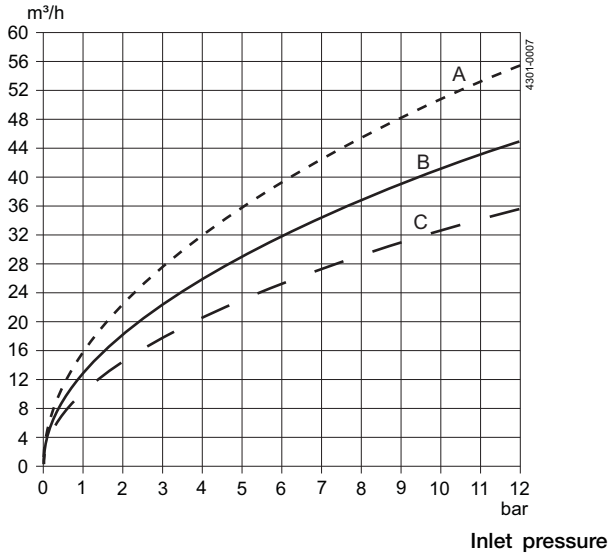

- Nozzles
- A) d = 10 mm
 - B) d = 9 mm
 - C) d = 8 mm

Reach of jet

Reach of jet for the IM 20 during cleaning, and indicative reach of jet for mixing of liquids with water-like properties.

Reach of jet [m]

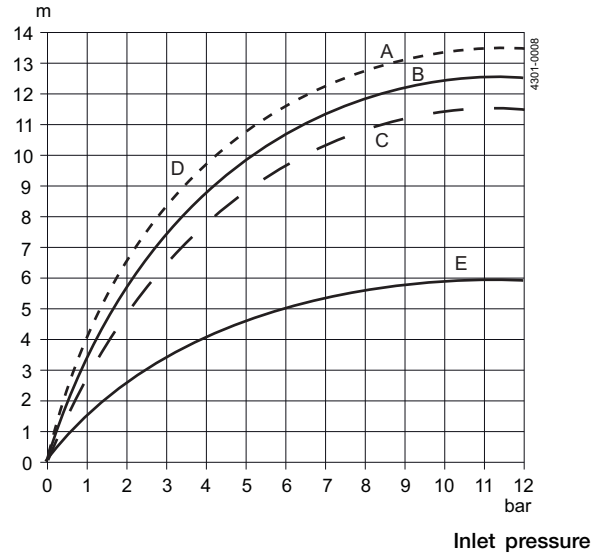

- Nozzles
- A) d = 10 mm
 - B) d = 9 mm
 - C) d = 8 mm
- Applications
- D) Cleaning
 - E) Mixing

Dimensions (mm)

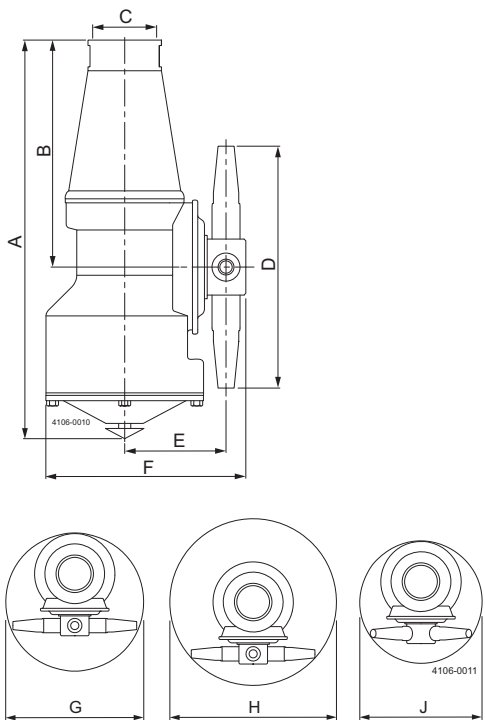

A	B	C	D	E	F	G	H	J
356	220	65	268	98	195	ø280	ø343	ø232

The Rotary Jet Mixing technology

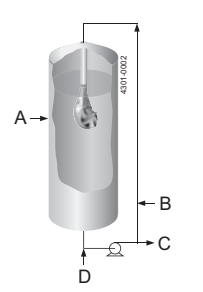

- A = Rotary Jet Mixer
- B = Gas
- C = Product
- D = Liquid feed

Traditional Mixing technology

Round pumping Propeller mixing

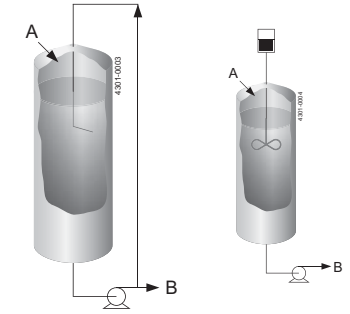

- A = Liquid feed
- B = Product

Alfa Laval reserves the right to change specifications without prior notification.

How to contact Alfa Laval

Contact details for all countries are continually updated on our website. Please visit www.alfalaval.com to access the information direct.