

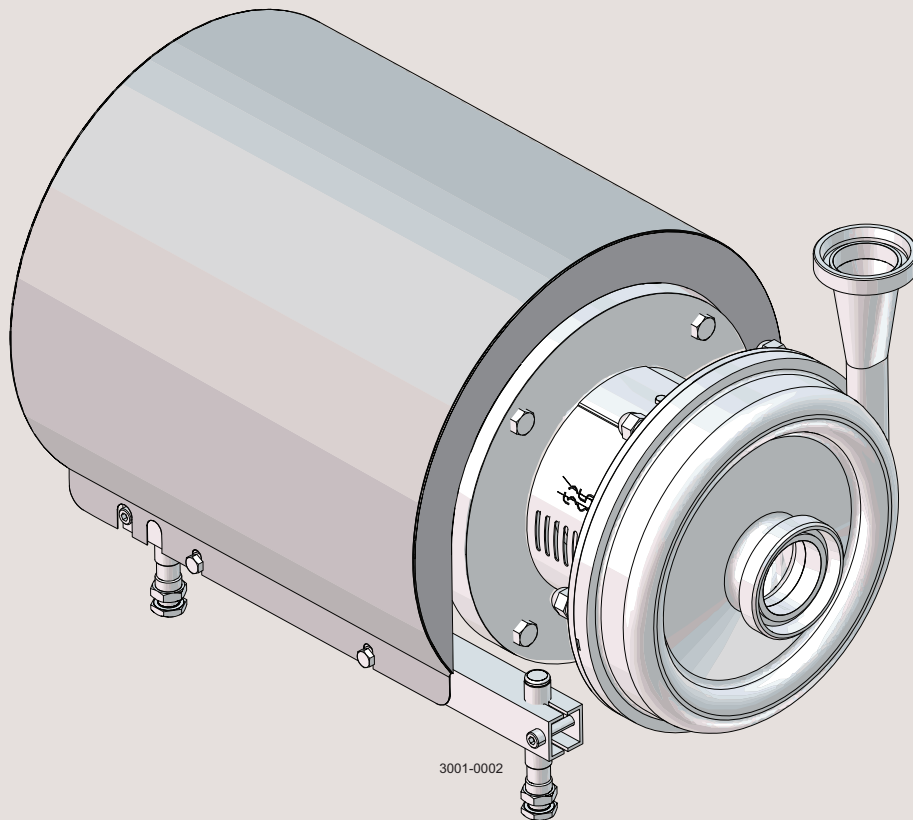

Instruction Manual

LKHex Centrifugal Pump



ESE02224-EN10 2017-12

Original manual

The information herein is correct at the time of issue but may be subject to change without prior notice

1. EU Declaration of Conformity	4
1.1. ATEX Directive 2014/34/EU	5
1.2. ATEX Marking	6
2. Safety	8
2.1. Important information	8
2.2. Warning signs	8
2.3. Special conditions for safe use	9
2.4. Safety precautions	12
3. Installation	14
3.1. Unpacking/delivery	14
3.2. Installation	15
3.3. Pre-use check - pump without impeller screw	17
3.4. Pre-use check with impeller screw	18
3.5. Recycling information	19
4. Operation	20
4.1. Important check and monitoring during operation	20
4.2. Operating conditions	21
4.3. Operation/Control	22
4.4. Trouble shooting	24
4.5. Recommended cleaning	25
5. Maintenance	26
5.1. General maintenance	26
5.2. Dismantling of pump/shaft seals	28
5.3. Assembly of pump/single shaft seal	30
5.4. Assembly of pump/double mechanical shaft seal	32
5.5. Adjustment of shaft (LKHex-10 to -70)	35
6. Technical data	37
6.1. Technical data	37
6.2. Technical information and description of mechanical shaft seals	38
6.3. Torque specifications	39
6.4. Weight (kg)	39
6.5. Noise emission	40
6.6. Relubrication intervals	41
7. Parts list	42
7.1. Drawing LKHex-10, -15, -20, -25, -35, -40, -45, -50, -60, -70 sanitary version	42
7.2. LKHex - Wet end (LKH-10 -70)	44
7.3. LKHex - Motor dependent parts (LKH-10 - 70)	46
7.4. LKHex - Shaft seal	48

1 EU Declaration of Conformity

Alfa Laval certificate no.: 9612960001 X

This declaration of conformity is issued under sole responsibility of the manufacturer:

Alfa Laval Kolding A/S
Company Name

Albuen 31, 6000 Kolding,
Denmark
Address

+45 79 32 22 00
Phone No.

Equipment covered by this declaration of conformity:

Pump
Designation

LKHex-10, LKHex-15, LKHex-20, LKHex-25, LKHex-35, LKHex-40, LKHex-45, LKHex-50, LKHex-60, LKHex-70
Type

From serial number 212.000 to 1.000.000

is in conformity with the requirements of the following directives:

2006/42/EC Machinery Directive
2014/34/EU Equipment Explosive Atmospheres (ATEX)

Pump Marking Options:

For specific marking see pump name plate and refer to "Special Conditions for Safe Use" in instruction manual.

 II 2 G
Ex h IIB T4 Gb Ta -20C to +35C

 II 2 G
Ex h IIB T4 Gb

 II 2 G
Ex h IIB T3 Gb

For ATEX directive 2014/34/EU the following harmonized standards EN 80079-36:2016 and EN 80079-37:2016 for none electrical equipment have been applied.

ATEX directive 2014/34/EU conformity for the motor is covered by the relevant EU Type examination certificate and declaration supplied by the manufacturer.

The Pump Technical file is stored with: Teknologisk Institut, Kongsvang Allé 29, 8000 Aarhus C, Denmark

Notified Body no.: 0396

Archive no.: 2017-1-0270A

The person authorized to compile the technical file is the signer of this document

Global Product Quality Manager
Pumps, Valves, Fittings and Tank Equipment
Title
Alfa Laval Kolding, Albuen 31, DK 6000 Kolding
Place

Lars Kruse Andersen
Name
2017-12-01
Date

Signature

(This declaration of Conformity replaces Declaration of Conformity dated 2013-12-03)



1.1 ATEX Directive 2014/34/EU

ATEX Directive 2014/34/EU

The ATEX Directive 2014/34/EU covers equipment and protective systems that will be used in areas endangered by potentially explosive atmospheres created by the presence of flammable gases, vapours and dusts. Centrifugal pumps supplied with an ATEX symbol are classified for use in potentially explosive atmospheres under ATEX Directive 2014/34/EU Group II, Categories 2 and 3.

Technical File Ref: **LKHex - Document reference no. 9612-9600-01.**

Equipment Group and Category: **Group II category 2 G (zone 1)**

Standards used: **EN 80079-36:2016, EN 80079-37:2016**

1 EU Declaration of Conformity

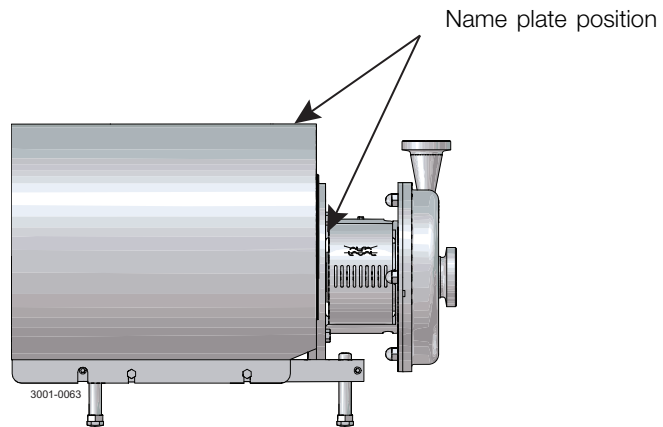

See marking options in chapter 2.3 Special conditions for safe use, table A.

2 Safety

*Unsafe practices and other important information are emphasised in this manual.
Warnings are emphasised by means of special signs.
Always read the manual before using the pump!*

2.1 Important information

WARNING

Indicates that special procedures must be followed to avoid serious personal injury.

CAUTION

Indicates that special procedures must be followed to avoid damage to the pump.

NOTE

Indicates important information to simplify or clarify procedures.

2.2 Warning signs

General warning:



Dangerous electrical voltage:



Caustic agents:



All warnings in the manual are summarised in this section.

Pay special attention to the instructions below so that severe personal injury and/or damage to the pump are avoided.

2.3 Special conditions for safe use

General warnings.

Always read chapter 4.2 Operating conditions.

Never run the pump with neither the suction side nor the pressure side blocked.

Always ensure that the pump is liquid filled when operating, unless a doubled mechanical seal is fitted (See table C).

Always ensure that the pump is liquid filled if the process media is flammable.

Never mount shroud on the pump if the name plate states "shroud not allowed".

Always stop the pump if



- operating outside the given limits of the process media temperature or flow rate (See table A and B).
- operating outside the given limits of the flush media temperature or flow rate (See table C).
- **Note** it must be ensured that the flow and temperature limits for the process media or flush media are maintained when the pump is operating. If this cannot be ensured in any other way, the flow and temperature should be continuously monitored.

Note In case of seal failure, leakage may occur. If this can lead to hazardous situations, the risk must be evaluated and necessary precautions must be taken. (See chapter 6.2 Technical information and description of mechanical shaft seals).

Note the motor is a separate certified ATEX product and covered by EU-type examination certificate and must be handled according to the specifications in the motor instruction manual.

Safety critical limitations for specific ATEX markings.

Table A

Pump marking options	Ambient temperature	Critical temperature range of process media
 II 2 G Ex h IIB T4 Gb Ta -20C to +35C	-20°C to +35°C (Shroud allowed) *3	-10°C to 100°C *1&2
 II 2 G Ex h IIB T4 Gb	-20°C to +40°C (Shroud NOT allowed)	
 II 2 G Ex h IIB T3 Gb	-20°C to +40°C (Shroud allowed)	-10°C to 140°C *1&2

*1 See table B for position of temperature sensor and min. flow rates.

*2 "b1" ignition control is used, see details in section below "b1 control system requirements".

*3 For pumps with temperature class T4 and with 18,5kW motors or larger, shroud is not allowed (independent of ambient temperature).

Note For T4 applications the pump casing and seal housing can be sterilized to max 125°C when the pump is NOT operating.

Note Ensure that the chosen elastomer is compatible with the process media and the media temperature (see chapter 4.2 for more information).

Note The LKHex can only be marked for category 2G but can be used for 3G applications also.

2 Safety

All warnings in the manual are summarised in this section.

Pay special attention to the instructions below so that severe personal injury and/or damage to the pump are avoided.

Requirements for measurements on the process media

There are two principles of temperature measurements of the process media:

- A. Temperature is measured on the pump outlet side (S1). No equipment with cooling effect on the process media is allowed between pump and sensor.
- B. Temperature is measured somewhere on the pump inlet side (S2). No heat generating equipment is allowed between the temperature sensor and the pump.

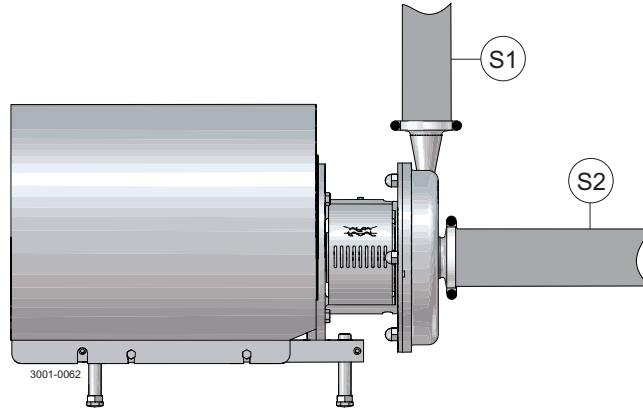

Table B Measurements on process media

Temperature sensor position	Model	Min. flow [m ³ /h]	Max. distance to outlet [m]
S1 (outlet side)	LKH10-70	0,5	0,5
	LKH10-60	1	10
	LKH70	5	10
S2 (inlet side)	LKH10-60	1	Anywhere on inlet side
	LKH70	5	

Requirements for measurements on the flush media (double mechanical shaft seal)

Table C Flush media limitations

Max. temperature	100°C
Min. flow rate	30 l/h
Max. pressure	5 bar

Note: Flush media temperature must be measured no more than 2m away from the flush housing outlet.

Pumps mounted with double mechanical shaft seals can operate without the pump casing being liquid filled at all times since the seal faces are lubricated and cooled by the flush media.

All warnings in the manual are summarised in this section.

Pay special attention to the instructions below so that severe personal injury and/or damage to the pump are avoided.

"b1" control system requirements

Measurement system shall be chosen according to EN-ISO 80079-37.

Always test and validate the control system before production start-up.

The ignition protection system performance requirements:

Temperatures:

- +/-2°C
- 30s reaction time

Flow:

- +/- 10%
- 30s reaction time

The demand for the ignition protection system b1 must be according to ISO 13849-1 PL c cat. 2 or IEC 61508 SIL 1 and must be calibrated and functionally tested on a yearly basis.

2 Safety

2.4 Safety precautions

General considerations

To prevent hazardous reactions between the processed fluid and the materials of construction, the materials of construction must be suitable for the application.
The auxiliary equipment chosen for the application must be suitable.

Education

Personnel installing, operating or carrying out maintenance on the pump or any sub-component must have the necessary knowledge about the LKHex pump range. Necessary knowledge includes the understanding of:

- Function of the pump, motor and shaft seal.
 - Maintenance/service of the pump unit, motor and shaft seal.
 - Operational limits for the LKHex pump range.
 - Safety instructions.
-

Installation

Always read the chapter 3 regarding installation carefully before installing the pump unit.

Always ensure that the pump unit is suitable for the application and will stay within the specifications in chapter 4.2

Operating conditions during normal operation.

Always read the technical data thoroughly. (See chapter 6 Technical data.)

Always use a lifting crane when handling the pump.

Always design the process system in a way so pressure shocks or over pressure is avoided.



Pump without impeller screw:

Always remove the impeller before checking the direction of rotation.

Never start the pump if the impeller is fitted and the pump casing is removed.



Pump with Impeller screw:

Never start in the wrong direction of rotation with liquid in the pump.

Always have the pump electrically connected by authorised personnel. (See the motor instruction)

Operation

Always read the chapter 4 Operation before the pump is started.

Always ensure that the pump is operated within the specifications given in chapter 4.2 Operating conditions.

Never touch the pump or the pipelines when pumping hot liquids or when sterilising.

Never run the pump with both the suction side and the pressure side blocked.

Never run the pump when partially installed or not completely assembled.

Necessary precautions must be taken if leakage occurs as this can lead to hazardous situations.



Always handle lye and acid with great care.

Never use the pump for products not mentioned in the Alfa Laval pump selection program.

Never restart the pump automatically after a system lockout. At restart, it must be ensured that the pump is running within the specifications given in chapter 4.2 Operating conditions.

The Alfa Laval pump selection program can be acquired from your local Alfa Laval sales company.



Maintenance

Always read the chapter 5 Maintenance before servicing the pump.

Always make sure that the specifications in chapter 4 Operation are met before the pump is put back into operation.

Always refer to the pump serial no. on the name plate when ordering spare parts to ensure correct spares.

Always read the technical data thoroughly. (See chapter 6 Technical data)

Never service the pump when it is hot.

Never service the pump if pressurised.

Always check for any abnormal sounds or running behaviors when starting up the pump after maintenance.

Always use Alfa Laval genuine spare parts.



Motors with grease nipples:

Always re-lubricate the motor according to the intervals specified on the motor name plate, see also 6 Technical data for relubrication intervals.

Always disconnect the power supply when servicing the pump.



Transportation

Transportation of the pump or the pump unit:

Never lift or elevate in any way other than described in this manual

Always drain the pump head and accessories of any liquid

Always ensure that no leakage of lubricants can occur

Always transport the pump in its upright position

Always ensure that the unit is securely fixed during transportation

Always use original packaging or similar during transportation

3 Installation

3.1 Unpacking/delivery

Step 1

Always use a lifting crane when handling the pump (see 6 Technical data).

CAUTION

Alfa Laval cannot be held responsible for incorrect unpacking.

WARNING:

Be aware that certain pump configurations can tilt, and therefore cause injuries to feet or fingers. The pump should be supported underneath the adaptor when not installed in the process line.

Check the delivery for:

1. Complete pump.
 2. Delivery note.
 3. Motor instructions.
 4. Test certificate, IF ORDERED!
-

Step 2

Remove any packing materials from the inlet and outlet.
Avoid damaging the inlet and outlet.
Avoid damaging the connections for flushing liquid, if supplied.

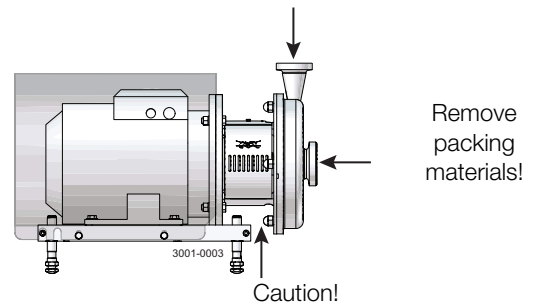

Step 3

Inspect the pump for visible transport damage.

Inspection!

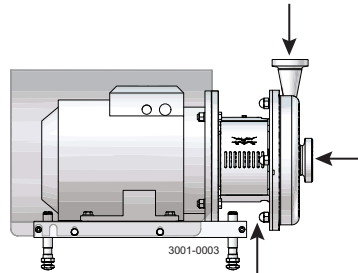

Step 4

Always remove the shroud, if fitted, before lifting the pump.

Remove the shroud before lifting!

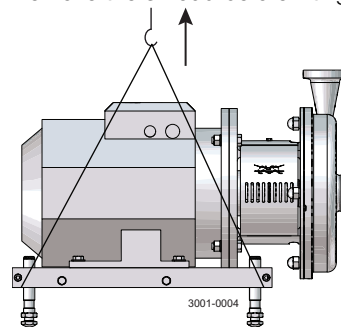

Read the instructions carefully and pay special attention to the warnings! Always check the pump before operation.
- See pre-use check in section 3.3 Pre-use check - pump without impeller screw.
The large pump sizes are very heavy. Alfa Laval therefore recommends the use of a lifting crane when handling the pump.

3.2 Installation

Step 1



Always read the technical data thoroughly. (See chapter 6 Technical data)

- Check nameplate and make sure that the pump is labelled according to the particular application where it is going to be used.
- In order to prevent the pump from operating under abnormal conditions, an ATEX-compliant protection system must be installed. The system must comply with EN ISO 80079-37:2016 or similar standards.
- Always use ATEX-compliant installation material.



Always use a lifting crane when handling the pump.



Always have the pump electrically connected by authorised personnel. (see the motor instructions).
The pump unit must be connected to earth before operation.

CAUTION

Alfa Laval cannot be held responsible for incorrect installation.

WARNING:

Alfa Laval recommends the installation of lockable repair breaker. If the repair breaker is to be used as an emergency stop, the colours of the repair breaker must be red and yellow.

CAUTION

The pump does not prevent back flow when intentionally or unintentionally stopped. If back flow can cause any hazardous situations, precautions must be taken e.g. check the valve to be installed in the system preventing hazardous situations from arising.

Step 2

Ensure at least 0.5 m (1.6 ft) clearance around the pump.

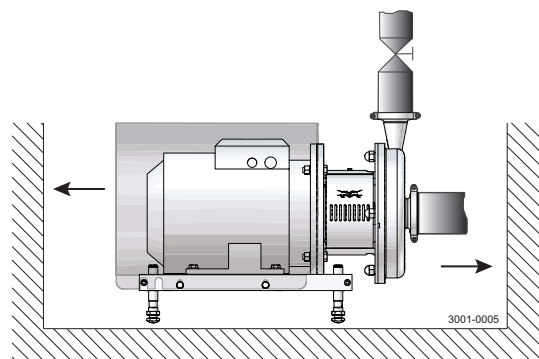

3 Installation

Read the instructions carefully and pay special attention to the warnings! Always check the pump before operation.
- See pre-use check in section 3.3 Pre-use check - pump without impeller screw.
The large pump sizes are very heavy. Alfa Laval therefore recommends the use of a lifting crane when handling the pump.

Step 3

Check that the flow direction is correct.

O: Outlet

I: Inlet

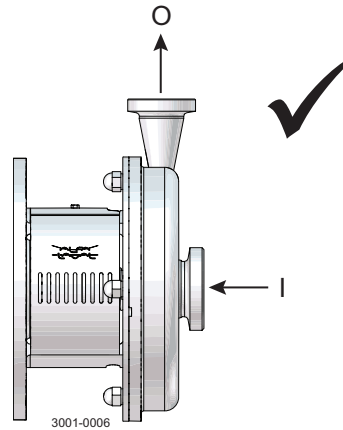

Step 4

1. Ensure that the pipelines are routed correctly.
2. Ensure that the connections are tight.

Remember seal rings!

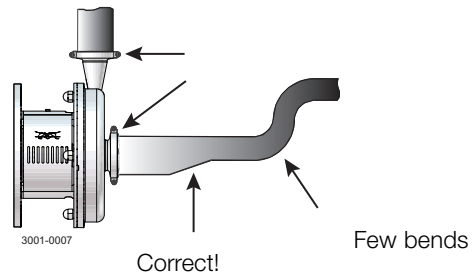

Step 5

Avoid stressing the pump.

Piping system must be self-supported

Pay special attention to:

- Vibrations.
- Thermal expansion of the tubes.
- Excessive welding.
- Overloading of the pipelines.

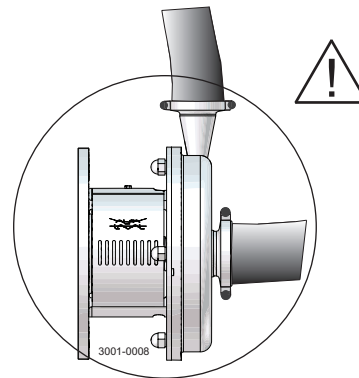

Note

In case of shaft seal leakage, the media will drip from the slot in the bottom of the adaptor. In case of shaft seal leakage, Alfa Laval recommends putting a drip tray underneath the slot to collect the leakage.

Read the instructions carefully and pay special attention to the warnings!
 LKHex-10 to -60 is without impeller screw as standard but can be supplied with one.
 Check the direction of rotation of the impeller before operation.
 - See the indication label on the pump.

3.3 Pre-use check - pump without impeller screw

Step 1



Always remove the impeller before checking the direction of rotation.



Never start the pump if the impeller is fitted and the pump casing is removed.

1. LKHex-10-60: Remove cap nuts (24), washers (24a) and pump casing (29).
2. Remove impeller (27) (see also instruction in section 5.3 Assembly of pump/single shaft seal).

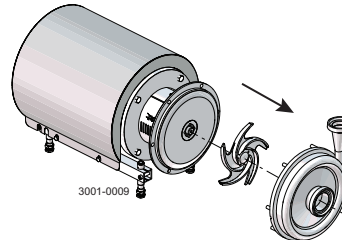

Step 2

1. Start and stop the motor momentarily.
2. Ensure that the direction of rotation of the stub shaft (7) is **anticlockwise** as viewed from the inlet side.

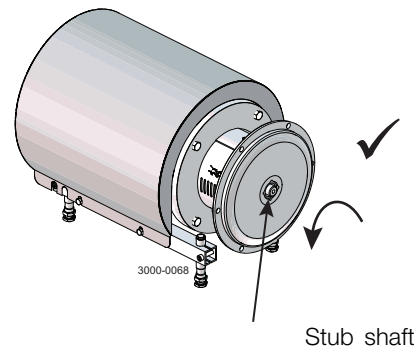

See the indication label!

Step 3

Fit and tighten impeller (27).

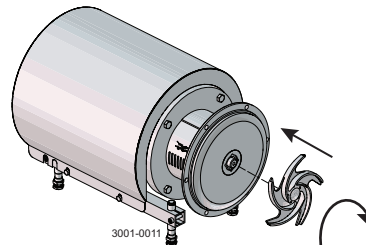

Step 4

1. Fit pump casing (29).
2. LKHex-10 to -60: Fit washers (24a) and tighten cap nuts (24).

Note:

Cap nuts must be tightened according to torque values in chapter 6 Technical data

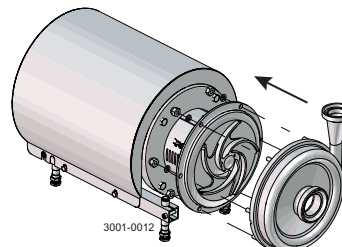

3 Installation

Read the instructions carefully and pay special attention to the warnings!
LKHex-10 to -60 is without impeller screw as standard but can be supplied with one.
Check the direction of rotation of the impeller before operation.
- See the indication label on the pump.

3.4 Pre-use check with impeller screw



Never start in the wrong direction of rotation with liquid in the pump.

1. Start and stop the motor momentarily.
2. Ensure that the direction of rotation of the motor fan is clockwise as viewed from the rear end of the motor.

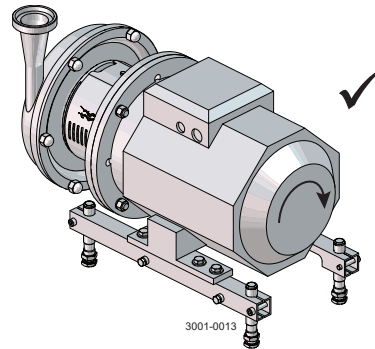

View from rear end of motor

Read the instructions carefully and pay special attention to the warnings!

LKHex-10 to -60 is without impeller screw as standard but can be supplied with one.

Check the direction of rotation of the impeller before operation.

- See the indication label on the pump.

3.5 Recycling information

Unpacking

- Packing material consists of wood, plastics, cardboard boxes and in some cases metal straps
- Wood and cardboard boxes can be re-used, recycled or used for energy recovery
- Plastics should be recycled or burnt at a licensed waste incineration plant
- Metal straps should be sent for material recycling

Maintenance

- During maintenance, oil and wearing parts in the machine are replaced
- All metal parts should be sent for material recycling
- Worn out or defective electronic parts should be sent to a licensed handler for material recycling
- Oil and all non-metal wearing parts must be disposed of in accordance with local regulations

Scrapping

- At the end of use, the equipment must be recycled according to relevant local regulations. Besides the equipment itself, any hazardous residues from the process liquid must be taken into consideration and dealt with in a proper manner. When in doubt, or in the absence of local regulations, please contact your local Alfa Laval sales company.
-

4 Operation

Read the instructions carefully and pay special attention to the warnings!

4.1 Important check and monitoring during operation

Daily checks

- Shaft seal (SSS and DMS)
If leakage from the shaft seal can lead to dangerous situations, daily visual inspection for leakage is recommended.
- If leakage is detected the risk should be evaluated and maintenance of the seal should be planned accordingly.

Other checks

Motor

- The bearing life is heavily dependent on the operating condition of the pump i.e. pressure, ambient temperature, motor load and pressure variations.
- The motor should be serviced according to the guidelines in the motor instruction manual
- The motor should be relubricated with the intervals given in chapter 6.6 "Relubrication intervals".

In order to detect motor bearing failure, the condition of the bearings must be monitored regularly.

It is recommended that the condition of the bearings is checked every 2000 hours of operation.

The condition of the bearings can be monitored in several ways eg. by means of vibration analysis (shock pulse measurements).

After checking the bearing condition, it must be evaluated if it is OK to continue or else maintenance of the bearings must be planned accordingly.

Read the instructions carefully and pay special attention to the warnings!

4.2 Operating conditions

General:				
Maximum ambient temperature:		-10°C to +35°C for T4, motor with shroud -10°C to +40°C for T4, motor without shroud -10°C to +40°C for T3		
Maximum pump speed:		3600 rpm		
Only Exd and Exde motors are designed to run with a variable speed drive (VDF). If VFD is used, the motor should be oversized by 10 % with regards to power output.				
Pump unit:				
Maximum inlet pressure	LKHex-10-60, 50/60 Hz	1000 kPa	(10 bar)	(145 psi)
Maximum inlet pressure	LKHex-70, 50 Hz	1000 kPa	(10 bar)	(145 psi)
Maximum inlet pressure	LKHex-70, 60 Hz	500 kPa	(5 bar)	(72 psi)
Note: Max inlet pressure is 5 bar in T4 applications when the process media is oil based				
Maximum product media temperature during normal operation for specific elastomers				
	Type of elastomer	Temperature class T4	Temperature class T3	
	EPDM	100°C / 212°F	130°C / 266°F	
	FPM	100°C / 212°F	140°C / 284°F	
	NBR	80°C / 176°F	80°C / 176°F	
	FEP encapsulated	100°C / 212°F	140°C / 284°F	
Minimum product temperature:		-10°C / 14°F		
Maximum product viscosity:		800 cP		
Shaft seal:				
Always read chapter 6 Technical data and ensure understanding of mechanical seal working principle				
Single shaft seal (SSS)				
- The SSS is lubricated and cooled by the processed media. It is therefore important to pay special attention to the operating limits of the pump unit.				
Double mechanical shaft seal (DMS)				
The DMS is lubricated by the product media and/or the flush media and the buffer or barrier flushing principle can be used				
		Minimum pressure of buffer/barrier fluid	Maximum pressure of buffer/barrier fluid	
	Buffer fluid*	> 0 bar / psi	5 bar / 72.5 psi**	
	Barrier fluid*	Pump inlet pressure plus 1 bar / 14.5 psi	5 bar / 72.5 psi	
* Description of the two systems can be found in chapter 6 Technical data				
** Pressure must be lower than the pump inlet pressure.				
If the viscosity of the processed media is less than 1 cP when using silicon carbide vs. silicon carbide, ONLY barrier fluid is applicable.				
Minimum flow rate of buffer/barrier fluid:		30 l/h (8 gal/h)		
Minimum temperature of buffer/barrier fluid:		-10°C / 14°F		
Maximum temperature of buffer/barrier fluid:		70°C (158°F) during operation ***		
*** When the pump is not in operation the flush system can be sterilized up to 125°C (260°F)				
For ATEX applications the pump should be stopped if the flush temperature measured at the outlet of the seal housing reaches 100°C (212°F)				

4 Operation

Read the instructions carefully and pay special attention to the warnings!

4.3 Operation/Control

Step 1



Always read the technical data thoroughly. See chapter 6 Technical data

CAUTION

Alfa Laval cannot be held responsible for incorrect operation/control.

Step 2



Never touch the pump or the pipelines when pumping hot liquids or when sterilising.



Danger of burns!

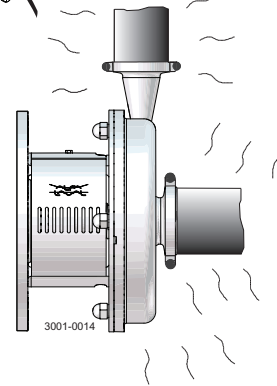

Step 3



Never run the pump with both the suction side and the pressure side blocked.

Danger of explosion!

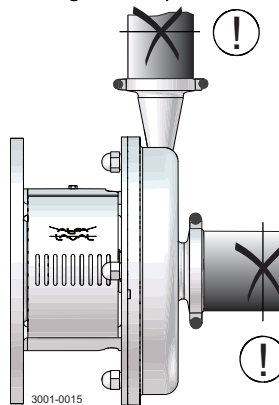

See warning label on pump

Read the instructions carefully and pay special attention to the warnings!

Step 4

CAUTION

The shaft seal must not run dry.

CAUTION

Never throttle the inlet side.
Pump casing **must** be completely filled before operation.

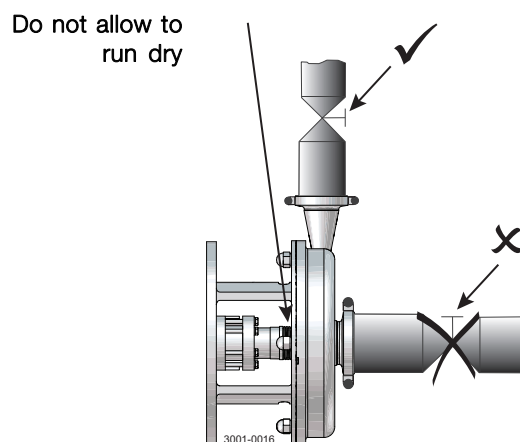

Step 5

Double mechanical shaft seal:

1. Connect the inlet of the flushing liquid correctly.
2. Read instructions in chapter 4.2 Operating conditions.
3. Regulate the water supply correctly.

O: Outlet

I: Inlet

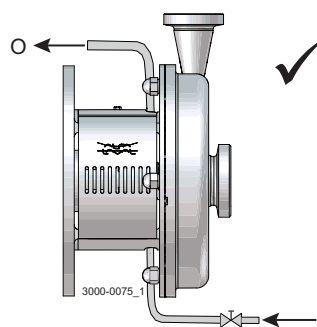

Step 6

Control:

Reduce the capacity and the power consumption by means of:

- Throttling the pressure side of the pump.
- Reducing the impeller diameter.
- Reducing the speed of the motor.

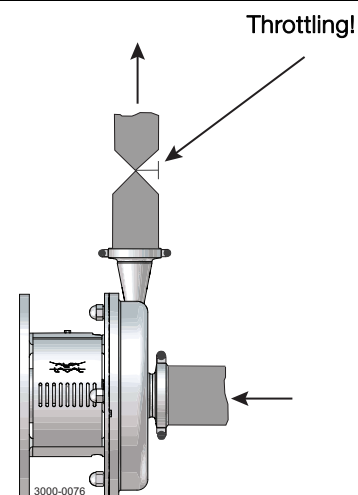

4 Operation

*Pay attention to possible faults.
Read the instructions carefully.*

4.4 Trouble shooting

NOTE!

Read the maintenance instructions carefully before replacing worn parts.

Problem	Cause/result	Remedy
Overloaded motor	<ul style="list-style-type: none">- Pumping of viscous liquids- Pumping of high density liquids- Low outlet pressure (counter pressure)- Lamination of precipitates from the liquid	<ul style="list-style-type: none">- Larger motor or smaller impeller- Higher counter pressure (throttling)- Frequent cleaning
Cavitation: <ul style="list-style-type: none">- Damage- Pressure reduction (sometimes to zero)- Increase in the noise level	<ul style="list-style-type: none">- Low inlet pressure- High liquid temperature	<ul style="list-style-type: none">- Increase the inlet pressure- Reduce the liquid temperature- Reduce the pressure drop before the pump- Reduce speed
Leaking shaft seal	<ul style="list-style-type: none">- Running dry- Incorrect rubber grade- Abrasive particles in the liquid	Replace: All wearing parts If necessary: <ul style="list-style-type: none">- Change rubber grade- Select stationary and rotating seal ring in silicon carbide/silicon carbide
Leaking O-ring seals	Incorrect rubber grade	Change rubber grade

The pump is designed for cleaning in place (CIP). CIP = Cleaning In Place.
 Read the instructions carefully and pay special attention to the warnings!
 NaOH = Caustic soda.
 HNO₃ = Nitric acid.

4.5 Recommended cleaning

Step 1



Always handle lye and acid with great care.

Caustic danger!



Always use rubber gloves!



Always use protective goggles!

Step 2



Never touch the pump or the pipelines when sterilising.

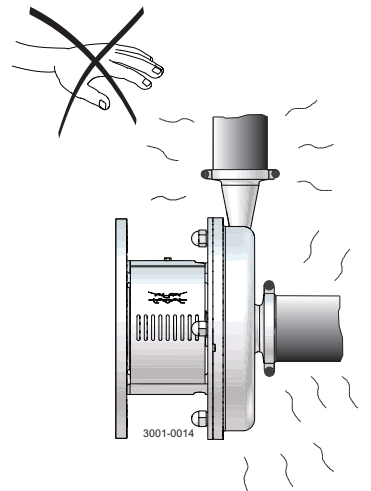

Danger of burns!

Step 3

Examples of cleaning agents: Use clean water, free from chlorides.

1. 1% by weight NaOH at 70°C (158°F).

1 kg (2.2 lb) NaOH	+	100 l (26.4 gal) water	= Cleaning agent.
-----------------------	---	---------------------------	-------------------

2.2 l (0.6 gal) 33% NaOH	+	100 l (26.4 gal) water	= Cleaning agent.
-----------------------------	---	---------------------------	-------------------

2. 0.5% by weight HNO₃ at 70°C (158°F).

0.7 l (0.2 gal) 53% HNO ₃	+	100 l (26.4 gal) water	= Cleaning agent.
---	---	---------------------------	-------------------

1. Avoid excessive concentration of the cleaning agent
 ⇒ Dose gradually!
2. Adjust the cleaning flow to the process.
 Sterilisation of milk/viscous liquids
 ⇒ Increase the cleaning flow!

Step 4



Always rinse well with clean water after using a cleaning agent.

Always rinse!

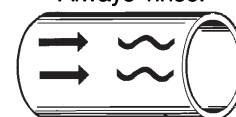

Clean water Cleaning agent

NOTE

The cleaning agents must be stored/disposed of in accordance with current regulations/directives.

5 Maintenance

Maintain the pump with care. Read the instructions carefully and pay special attention to the warnings!
Always keep spare shaft seals and rubber seals in stock.
See separate motor instructions.
Check the pump for smooth operation after service.

5.1 General maintenance

Step 1



Always use Alfa Laval genuine spare parts.
Always refer to the pump serial no. on the name plate when ordering spare parts to ensure correct spares.
Always read the technical data thoroughly. (See chapter 6 Technical data)
Always disconnect the power supply when servicing the pump.

NOTE

All scrap must be stored/disposed in accordance with current rules/directives.

Step 2



Never service the pump when it is hot.

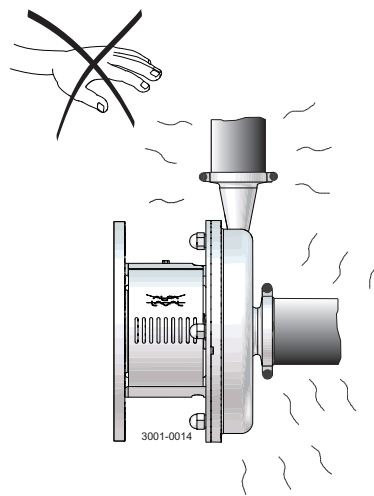

Danger of burns!

Step 3



Never service the pump if pressurised.

CAUTION

Fit the electrical connections correctly if they have been removed from the motor during service.

CAUTION

Pay special attention to the warnings!

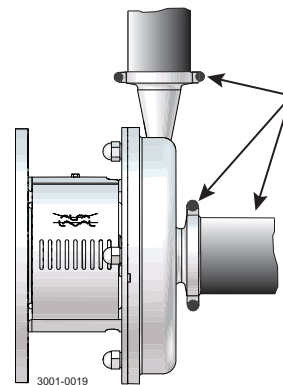

Atmospheric pressure required!

Step 4

Recommended spare parts:

Always refer to the pump serial no. on the name plate when ordering spare parts and service kits to ensure correct spares.
Order service kits from the service kits list (See chapter 7 Parts list and service kits).

Ordering spare parts

Contact your local Alfa Laval sales company.

Note:

If the pump is supplied with FEP O-rings, Alfa Laval recommends that the casing O-ring is replaced during pump maintenance.

5 Maintenance

Maintain the pump with care. Read the instructions carefully and pay special attention to the warnings!
 Always keep spare shaft seals and rubber seals in stock.
 See separate motor instructions.
 Check the pump for smooth operation after service.

	Shaft seal	Rubber seals	Motor bearings
Preventive maintenance	Replace after 12 months: (one-shift) Complete shaft seal	Replace when replacing the shaft seal	
Maintenance after leakage (leakage normally starts slowly)	Replace at the end of the day: Complete shaft seal	Replace when replacing the shaft seal	
Planned maintenance	<ul style="list-style-type: none"> - Regular inspection for leakage and smooth operation - Keep a record of the pump - Use the statistics for inspection planning Replace after leakage: Complete shaft seal	Replace when replacing the shaft seal	Yearly inspection is recommended <ul style="list-style-type: none"> - Replace complete bearing if worn - Ensure that the bearing is axially locked (See motor instructions)
Lubrication	Before fitting Lubricate the O-rings with silicone grease or silicone oil	Before fitting Silicone grease or silicone oil	See section 6.6 Relubrication intervals

Pre-use check

CAUTION!

Fit the electrical connections correctly if they have been removed from the motor during service.
 (See Pre-use check in section 3 Installation).

Pay special attention to warnings!

1. Start and stop the motor momentarily
2. Ensure that the pump operates smoothly.

5 Maintenance

Read the instructions carefully. The items refer to the parts list and service kits section.

Handle scrap correctly.

* : Relates to the shaft seal.

5.2 Dismantling of pump/shaft seals

Step 1

1. LKHex-10 to -70: Unscrew cap nuts (24) and remove washers (24a) and pump casing (29).

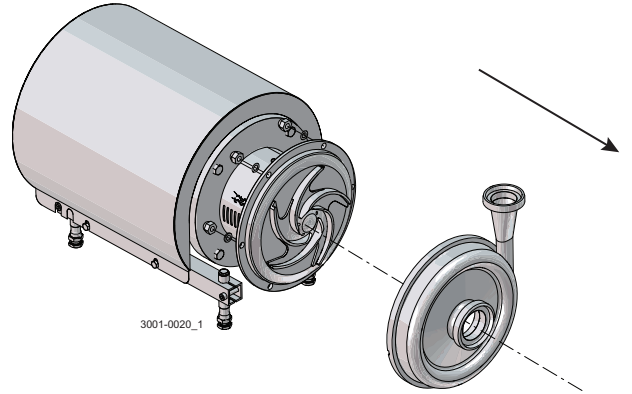

Step 2

Double mechanical shaft seal:

- Unscrew tubes (42) using a spanner.

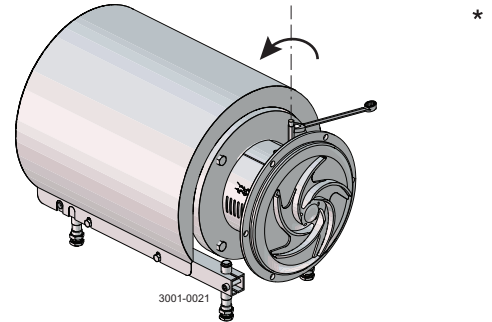

Step 3

- Remove screw (23) and safety guard (22).

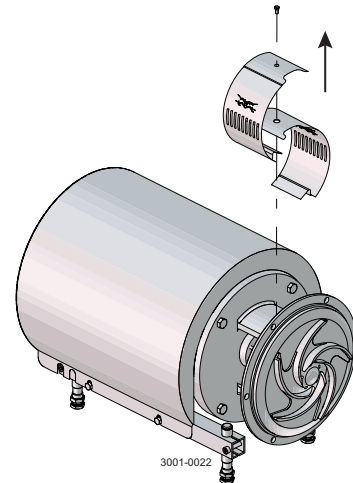

Step 4

1. Remove impeller screw (36), if fitted.
2. Remove impeller (27). If necessary, loosen the impeller by knocking gently on the impeller vanes.
3. Remove the O-ring (38) from the impeller, if fitted.

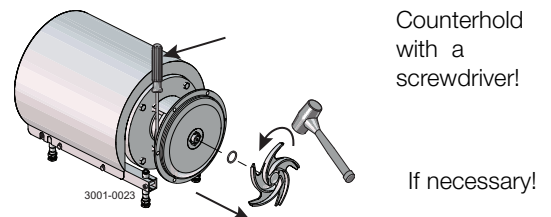

Counterhold with a screwdriver!

If necessary!

Read the instructions carefully. The items refer to the parts list and service kits section.

Handle scrap correctly.

* : Relates to the shaft seal.

Step 5

1. Pull off the O-ring (26) from back plate (25).
2. Unscrew nuts (20) and remove washers (21) and the back plate.

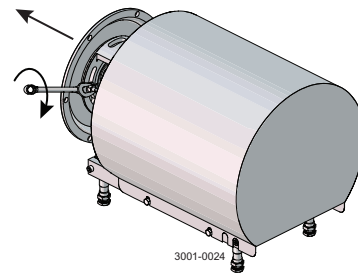

Step 6

1. Remove the stationary seal ring (11).
2. Remove the O-ring (12) from back plate (25).

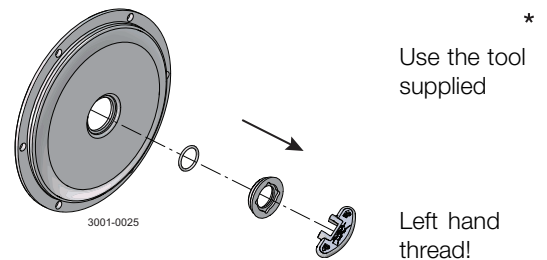

Step 7

Double mechanical shaft seal:

1. Remove screws (41) and seal housing (40a).
2. Remove rotating seal rings (14) and drive ring (52) from spring (13).
3. Remove O-rings (15) from rotating seal rings (14).
4. LKH-70: Remove cups (54) from rotating seal rings.

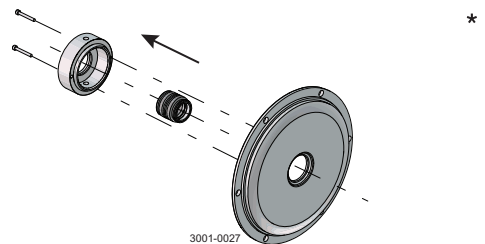

Step 8

Double mechanical shaft seal:

1. Remove stationary seal ring (51) from seal housing (40a).
2. Remove O-ring (50) from stationary seal ring (51).
3. Remove O-ring (44) from seal housing (40a).

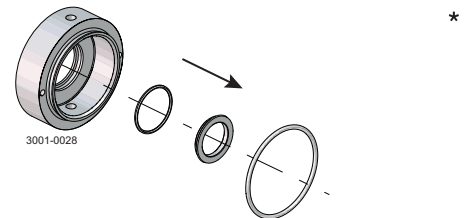

Step 9

1. Remove the complete shaft seal from stub shaft (7).
2. Remove spring (13) and rotating seal ring (14) from the drive ring (10).

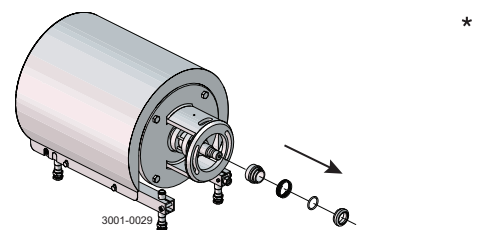

5 Maintenance

Read the instructions carefully. The items refer to the parts list and service kits section.

Handle scrap correctly.

* : Relates to the shaft seal.

5.3 Assembly of pump/single shaft seal

Step 1

1. Remove spring (13).

NOTE!

Make sure that O-ring (15) has maximum clearance from the sealing surface.

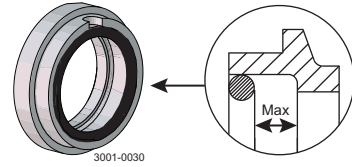

*

Step 2

1. Refit spring (13) on rotating seal ring (14).
2. Fit the spring and the rotating seal ring on drive ring (10).

CAUTION

Ensure that the driver on the drive ring enters the notch in the rotating seal ring.

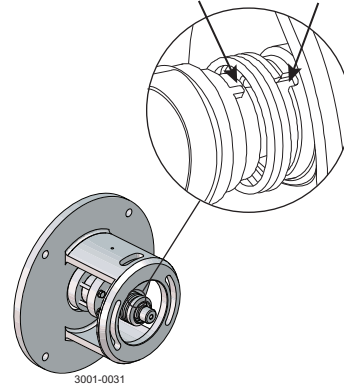

*

Step 3

- Fit the complete shaft seal on stub shaft (7).

NOTE!

Make sure that Connex pin (8) on the stub shaft enters the notch in drive ring (10).

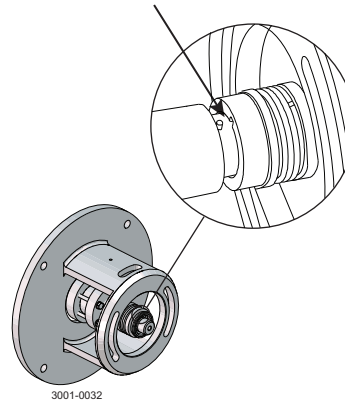

*

Step 4

1. Fit O-ring (12) on stationary seal ring (11) and lubricate.
2. Screw the stationary seal ring into back plate (25).

CAUTION

Only tighten by hand to avoid deforming the stationary seal ring.
(Max. 7 Nm/5 lbf-ft)

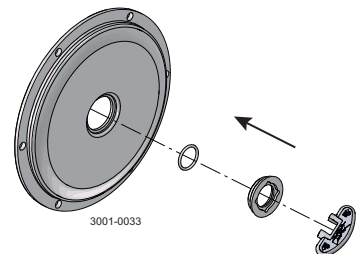

Use the tool
supplied

Left hand
thread!

*

Read the instructions carefully. The items refer to the parts list and service kits section.

Handle scrap correctly.

* : Relates to the shaft seal.

Step 5

1. Clean the sealing surfaces with contact cleaner before fitting back plate (25).
2. Carefully guide the back plate onto adaptor (16).
3. Fit washers (21) and nuts (20).

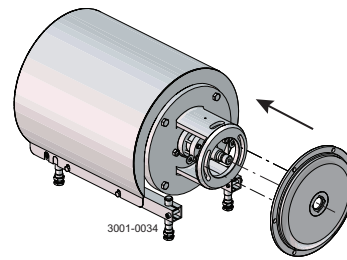

Step 6

Lubricate O-ring (26) and slide it onto back plate (25).

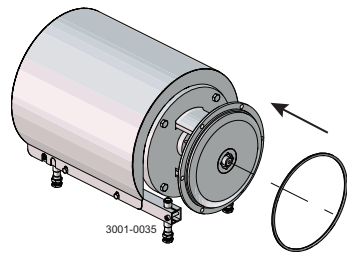

Step 7

1. Lubricate O-ring (38) and fit it in impeller (37), if impeller screw is used.
2. Lubricate impeller hub with silicone grease or oil.
3. Screw the impeller onto stub shaft (7).
4. Fit impeller screw (39) and tighten, if used.

Tightening torque for impeller screw:

LKHex 10-60: 20 Nm (15 lbf-ft)

LKHex 70: 50 Nm (37 lbf-ft)

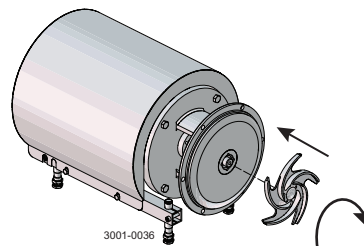

Step 8

Fit safety guards (22) and screw (23) and tighten.

If the pump is not supplied with flush connections, the holes in the adaptor will be covered by the guard.

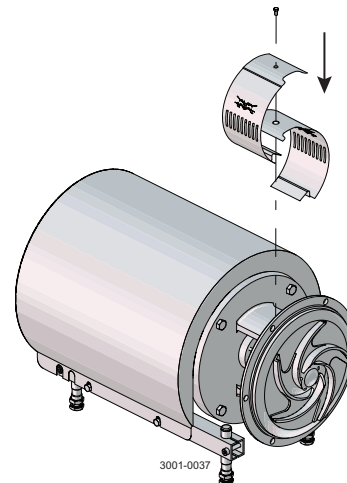

Step 9

1. LKHex-10 to -70: Fit pump casing (29), washers (24a) and cap nuts (24).
2. Adjust the pump casing to the right position.
3. LKH-10 to -70: Tighten nuts (20) for back plate (25) and tighten cap nuts (24).

Note:

Cap nuts must be tightened according to torque values in the chapter 6 Technical data

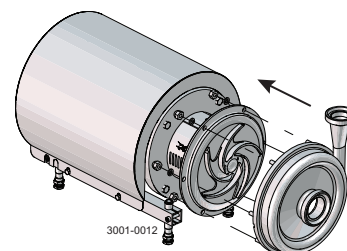

5 Maintenance

Read the instructions carefully. The items refer to the parts list and service kits section.

Lubricate the rubber seals before fitting them.

* : Relates to the shaft seal.

5.4 Assembly of pump/double mechanical shaft seal

Step 1

1. Fit O-rings (15) in rotating seal rings (14). *
2. LKH-70: Fit cups (54) on rotating seal rings (14).
3. Fit spring (13) on one of the rotating seal rings (14) and place the drive ring (52) in between.

Step 2

1. LKH-70: Turn the drive ring (52) in order to place it correctly on the pump shaft (7). *
2. Fit the second rotating ring (14) on the other end of the spring.
3. Place the parts on the stationary seal ring fitted in back plate (25).

NOTE

Ensure that both drive pins on the drive ring enter the notches in the rotating seal rings.

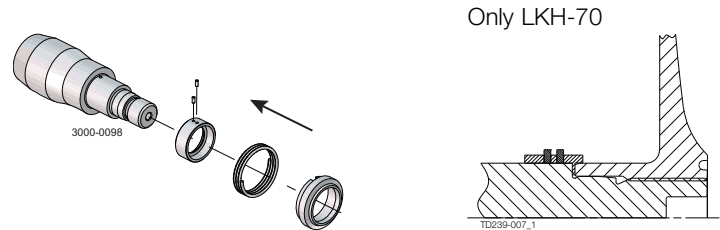

Step 3

1. Lubricate O-ring (44) and slide onto seal housing (40a). *
2. Lubricate O-ring (50) and fit on stationary seal ring (51) and fit this in the seal housing.

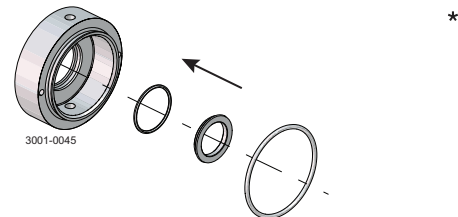

Step 4

1. Clean the sealing surfaces with contact cleaner.
2. Fit seal housing (40a) on the back plate (25) and tighten screws (41). *

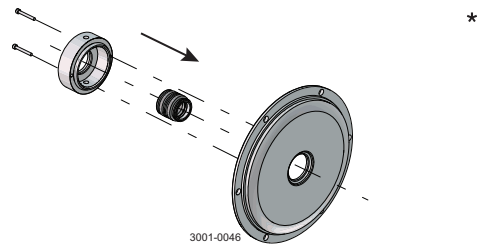

Step 5

1. To enable fitting of the back plate (25) with the shaft seal, remove Connex pin (8) from stub shaft (7) (if fitted).
2. Carefully guide the back plate onto adaptor (16).
3. Fit washers (21) and nuts (20).

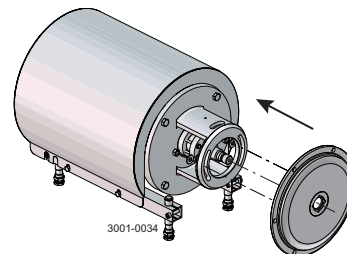

Read the instructions carefully. The items refer to the parts list and service kits section.
Lubricate the rubber seals before fitting them.
* : Relates to the shaft seal.

Step 6

Lubricate O-ring (26) and slide it onto back plate (25).

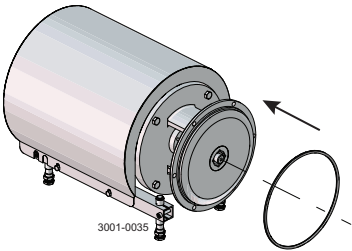

Step 7

- 1. Lubricate O-ring (38) and fit it in impeller (37), if impeller screw is used.
- 2. Lubricate the impeller hub with silicone grease or oil.
- 3. Screw impeller (27) onto stub shaft (7).
- 4. Fit impeller screw (36) and tighten, if used.

LKHex 10-60: 20 Nm (15 lbf-ft)
LKHex 70: 50 Nm (37 lbf-ft)

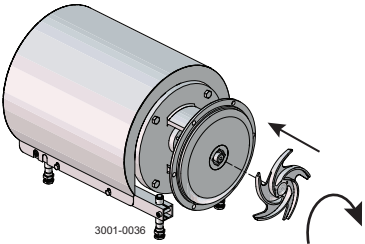

Step 8

- 1. Screw tubes (42) into seal housing (40a).
- 2. Tighten with a spanner.

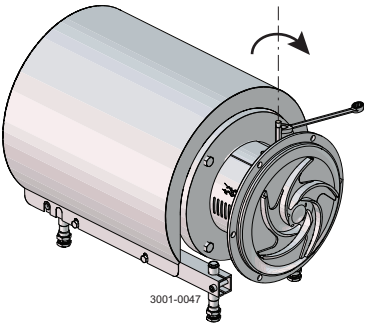

Step 9

Fit safety guard (22) and screw (23) and tighten.

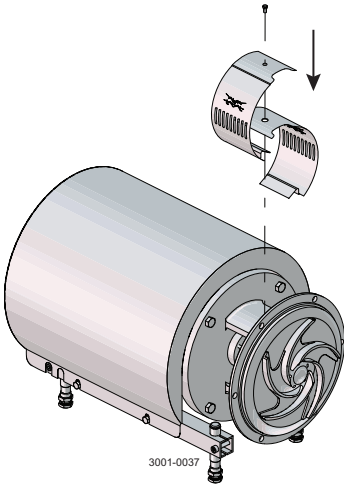

5 Maintenance

Read the instructions carefully. The items refer to the parts list and service kits section.

Lubricate the rubber seals before fitting them.

* : Relates to the shaft seal.

Step 10

1. Fit pump casing (29).
2. Tighten nuts (20) for back plate (25).
3. Fit washers (24a) and cap nuts (24) and tighten.

Note:

Cap nuts must be tightened according to torque values in chapter 6 Technical data

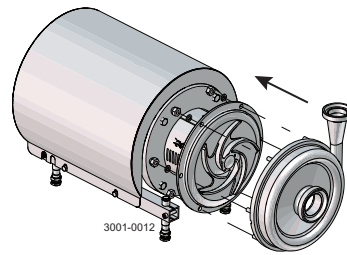

Read the instructions carefully. The items refer to the parts list and service kits section.
Lubricate the rubber seals before fitting them.
* : Relates to the shaft seal.

5.5 Adjustment of shaft (LKHex-10 to -70)

For securing the best fixture to the motor shaft ensure the following:

- Conical surfaces on the pump shaft and compression rings are applied with grease.
- No grease on the motor shaft.
- No grease on the inside diameter of the pump shaft.
- Screws for the compression rings are applied with grease.

Step 1

1. Loosen screws (6).
2. Pull off stub shaft (7) together with compression rings (5a, 5b).

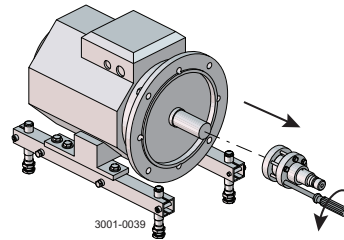

Step 2

1. Push stub shaft (7) together with compression rings (5a, 5b) onto the motor shaft.
2. Check that the clearance between the end of the stub shaft and the motor flange is 10-20mm (0.39-0.78 inch).

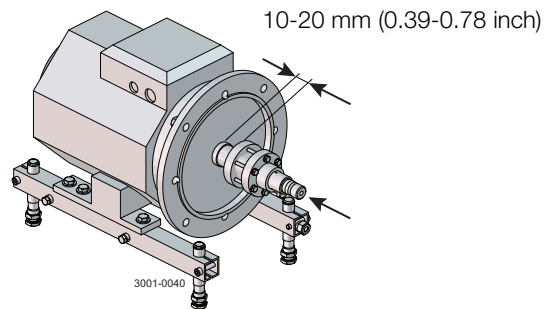

Step 3

1. Tighten screws (6) lightly and evenly.
2. Ensure that stub shaft (7) can be moved on the motor shaft.

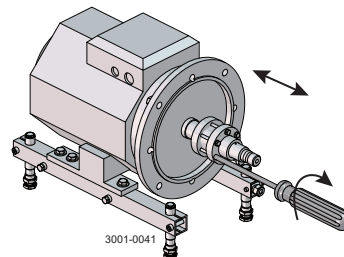

Step 4

1. For a double mechanical shaft seal: Fit drive ring (52) on stub shaft (7).
2. Fit back plate (25), washers (21) and nuts (20) and tighten.

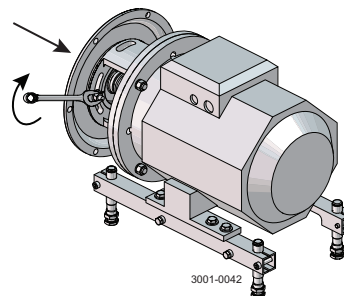

5 Maintenance

Read the instructions carefully. The items refer to the parts list and service kits section.

Lubricate the rubber seals before fitting them.

* : Relates to the shaft seal.

Step 5

1. Fit impeller (27) on stub shaft (7).
2. Ensure that the clearance between the impeller and back plate (25) is correct: 0.5mm (0.02 inch) for LKHex-10-60 and 1.0mm (0.04 inch) for LKHex-70.
3. Tighten screws (6) evenly until the stub shaft (7) cannot move on the motor shaft.

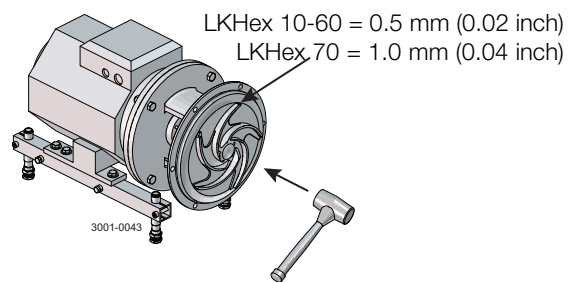

Step 6

1. Remove impeller (27), back plate (25) and drive ring (52).
2. Tighten screws (6) evenly to 15 Nm (11 lbf-ft).

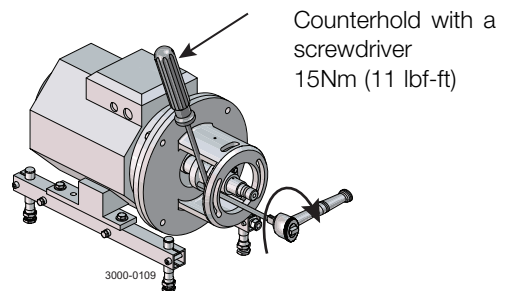

*It is important to observe the technical data during installation, operation and maintenance.
Inform personnel about the technical data.*

6.1 Technical data

The LKH pump is a highly efficient and economical centrifugal pump, which meets the requirements of sanitary and gentle product treatment and chemical resistance. The LKH pump is available in the following sizes LKHex -10, -15, -20, -25, -35, -40, -45, -50, -60 and -70. The instruction manual is part of the delivery. Study the instructions carefully. The large pump sizes are very heavy. Alfa Laval therefore recommends the use of a lifting crane when handling the pump.

Materials	
Product wetted steel parts	AISI 316L
Other steel parts	Stainless steel
Product wetted O-rings	EPDM (standard)
Other O-rings	EPDM (standard)
Alternative material, O-rings	Nitrile (NBR), fluorinated rubber (FPM) and FEP
Material, stationary seal ring	Acid-resistant steel with sealing surface of silicon carbide
Material, rotating seal ring	Carbon (standard) or silicon carbide

Motor	
Foot-flanged motor acc. to IEC metric standard 2 poles = 3000/3600 rpm at 50/60 Hz	
Motor sizes (kW), 50/60 Hz	1.5 - 75 kW

For further information, see PD sheet.

6 Technical data

*It is important to observe the technical data during installation, operation and maintenance.
Inform personnel about the technical data.*

6.2 Technical information and description of mechanical shaft seals

General considerations regarding mechanical shaft seals

The basic working principle of a mechanical seal is that the seal faces are cooled and lubricated by the process media or the flush media.

If the seal faces are not cooled and lubricated, the temperature of the faces will increase to be above the temperature at normal running conditions. This is referred to as "dry running".

Dry running will shorten the lifetime of the seal and eventually cause the seal to fail. Dry running is not allowed in ATEX applications.

Due to this working principle, there will be a small controlled leakage from the seal during normal operation. This leakage will increase if seal failure occurs. When a seal is failing the degree of leakage can go from a drop leakage to a flush leakage depending on the type of failure.

Note: The risk of leakage from a failing seal must be considered if pumping flammable products or other products where leakage can lead to hazardous situations.

Single mechanical shaft seal (SSS)

The SSS is cooled and lubricated by the process media.

The process media must always be present during operation to avoid dry running.

The Critical temperature range and the minimum flow rate of the process media are stated in chapter "2 Special conditions for safe use".

Double mechanical shaft seal (DMS)

If continuous presence of process media cannot be guaranteed or leakage of the process media is unacceptable, a DMS should be applied.

The DMS is cooled and lubricated by the process media and/or the flush media.

Flush media must always be present during operation of the pump to avoid dry running.

Requirements for minimum flows and max temperatures of the flush media are stated in chapter "2 Special conditions for safe use".

There are two basic flush principles for DMS:

- Buffer fluid system having a pressure lower than the pumped media.
This principle will flush away possible solidifications and residues from the primary seal. It is the product media which lubricates the primary seal faces and the flush media lubricating the secondary seal faces.
- Barrier fluid system having a pressure of minimum 1bar above the pump inlet pressure.
This principle will cool and lubricate both the primary and secondary seal.
The barrier principle can be used in many applications but should be used if the seal configuration is SiC/SiC and the process media viscosity is less than 1cP.

*It is important to observe the technical data during installation, operation and maintenance.
Inform personnel about the technical data.*

6.3 Torque specifications

The table below specifies the tightening torques for the screws, bolts and nuts in this pump.
Always use the following torques if no other values are stated. This can be a matter of personal safety.

Size	Tightening torque	
	Nm	lbf-ft
M8	20	14.8
M10	40	29.5
M12	67	49.0
M14	110	81.0

6.4 Weight (kg)

Pump Type: LKHex

Size	90		100		112		132		160		180		200		250	
	1.5kW	2.2kW	3kW	4kW	5.5kW	7.5kW	11kW	15kW	18.5kW	22kW	30kW	37kW	45kW	55kW	75kW	
10	53	55	70	75												
15			73	78	95											
20	55	57	72	77	94	108										
25				81	98	112	171	185								
35				81	98	112	171	185								
40						115	174	188	206	225						
45				82	99	113	172	186								
50					101	115	174	188	206	225						
60					102	116	175	189	207	226	334					
70					138	152	196	210	228	259	365	380	396	522	557	

Weight can vary depending of configuration. Weight is only to be seen as a reference value during handling, transporting and packaging.

6 Technical data

*It is important to observe the technical data during installation, operation and maintenance.
Inform personnel about the technical data.*

6.5 Noise emission

Pump type	Sound pressure level (dBA)
LKHex-10	69
LKHex-15	72
LKHex-20	70
LKHex-25	74
LKHex-35	71
LKHex-40	75
LKHex-45	70
LKHex-50	75
LKHex-60	77
LKHex-70	88

The noise measurements are carried out using the original motor and shroud, at the approximate Best Efficiency Point (BEP) with water at ambient temperature and at 50Hz.

Very often, the noise level generated by the flow through the process system (e.g. valves, pipes, tanks etc.) is much higher than that generated by the pump itself. Therefore, it is important to consider the noise level from the total system and take the necessary precautions with regard to personal safety if required.

*It is important to observe the technical data during installation, operation and maintenance.
Inform personnel about the technical data.*

6.6 Relubrication intervals

The table is for an internal bearing temperature of 100°C. An increase in temperature of 15°C (ambient or internal in bearings), will reduce the greasing interval and bearing lifetime by 50%. The lubrication interval for vertically mounted pumps is half the value stated in the table.

WEG IEC Motors

Motor Power (kW)	LKHex (Exd/Exde)	Motor power (kW)	LKHex (Exe)
50/60 Hz			50/60 Hz
1.5	Permanently lubricated	1.85	Permanently lubricated
2.2	Permanently lubricated	2.5	Permanently lubricated
3.0	Permanently lubricated	3.3	Permanently lubricated
4.0	Permanently lubricated	4.6	Permanently lubricated
5.5	Permanently lubricated	5.5	Permanently lubricated
7.5	Permanently lubricated	7.5	10000/10000h - DE/NDE: 13g
11	Permanently lubricated	12.5	10000/10000h - DE/NDE: 13g
15	Permanently lubricated	15	10000/10000h - DE/NDE: 18g
18.5	Permanently lubricated	20	10000/10000h - DE/NDE: 21g
22	10000/10000h - DE/NDE: 18g	24	10000/10000h - DE/NDE: 21g
30	10000/10000h - DE/NDE: 21g	36	4500/4500h - DE/NDE: 27g
37	10000/10000h - DE/NDE: 21g	47	4500/4500h - DE/NDE: 27g
45	Not available	58	4500/4500h - DE/NDE: 27g
55	4500/4500h - DE/NDE: 27g		
75	4500/4500h - DE/NDE: 27g		

Recommended grease types:

POLYREX EM 103

7 Parts list

The drawing shows the LKHex, sanitary version.

Always use Alfa Laval genuine spare parts.

Always refer to the pump serial no. on the name plate when ordering spare parts to ensure correct spares.

7.1 Drawing LKHex-10, -15, -20, -25, -35, -40, -45, -50, -60, -70 sanitary version

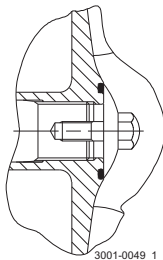
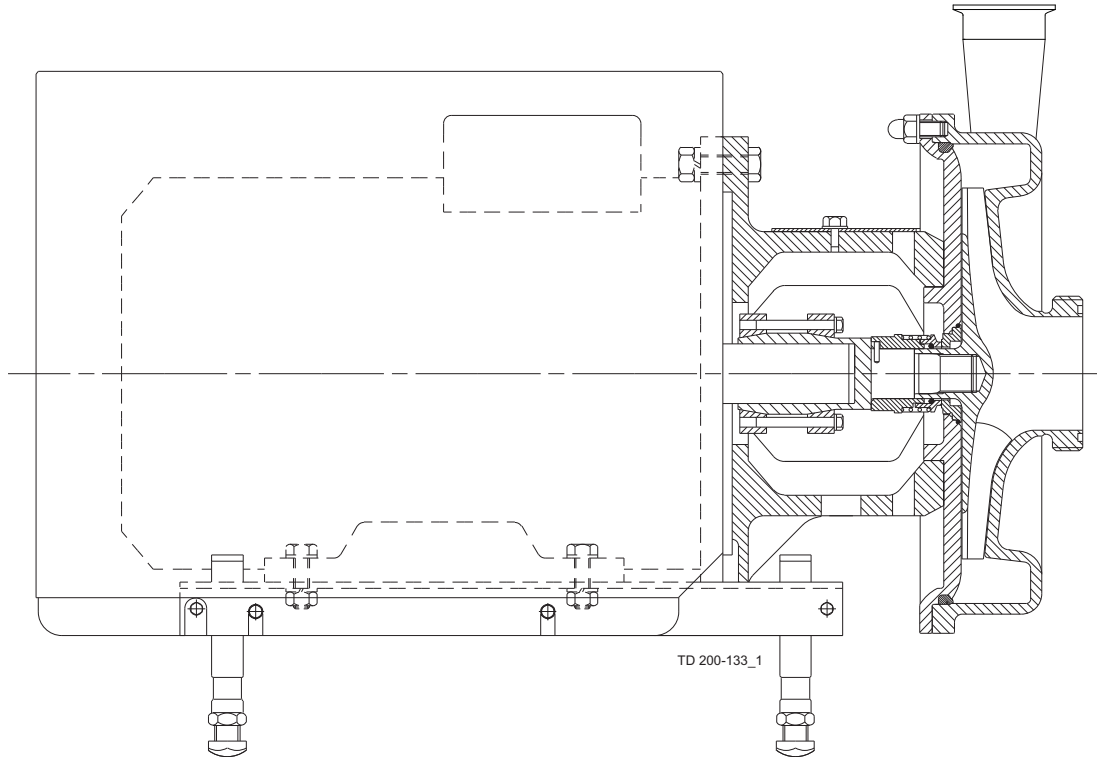

Impeller screw

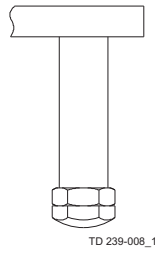

Fitting of legs
Exe 36 - 58 kW
Exde 55 - 75 kW

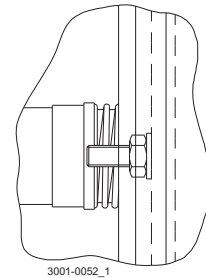

Fitting of back plate

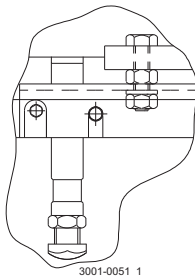

Only used for fitting of legs
Exe 2.5 kW
Exde 2.2 - 3 kW

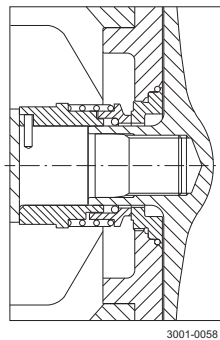

Single shaft seal

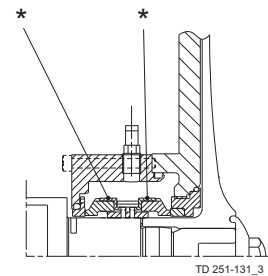

* Double mechanical shaft seal

The drawing shows the LKHex, sanitary version.

Always use Alfa Laval genuine spare parts.

Always refer to the pump serial no. on the name plate when ordering spare parts to ensure correct spares.

Parts list

Pos.	Qty	Denomination
20	2	Nut
21	2	Washer
24	6	Cap nut
24a	6	Washer
25	1	Back plate
26	1	O-ring
27	1	Impeller
28	6	Bolt
29	1	Casing
36	1	Impeller screw
37	1	Impeller for impeller screw
38	1	O-ring

The drawing shows the LKHex, sanitary version.

Always use Alfa Laval genuine spare parts.

Always refer to the pump serial no. on the name plate when ordering spare parts to ensure correct spares.

Parts list

Pos.	Qty	Denomination
		Shaft incl. pin and retaining
1	1	Motor
2	1	Shroud
3	4	Screw
5a	1	Compression ring
5b	1	Compression ring
6	6	Screw
6a	6	Washer
7	1	Shaft incl. pin
8	1	Connex pin
9	1	Retaining ring
16	1	Adaptor
17	4	Screw for adaptor
18	4	Nut for adaptor
19	4	Washer for adaptor
22	1	Safety guard set
23	1	Screw for safety guard
30a	1	Support bar
30b	1	Support bar
31	4	Leg
32	4	Screw
33	4	Nut
34	4	Spring washer
35	4	Screw
35a	4	Washer
39	4	Spacer for leg
46	4	Distance sleeve

7 Parts list

The drawing shows the LKHex, sanitary version.

Always use Alfa Laval genuine spare parts.

Always refer to the pump serial no. on the name plate when ordering spare parts to ensure correct spares.

7.4 LKHex - Shaft seal

Single shaft seal

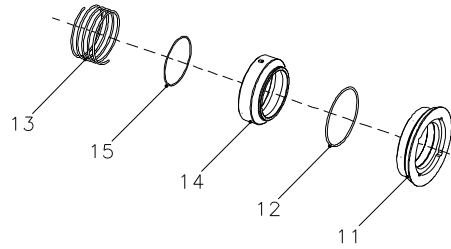

Double mechanical shaft seal

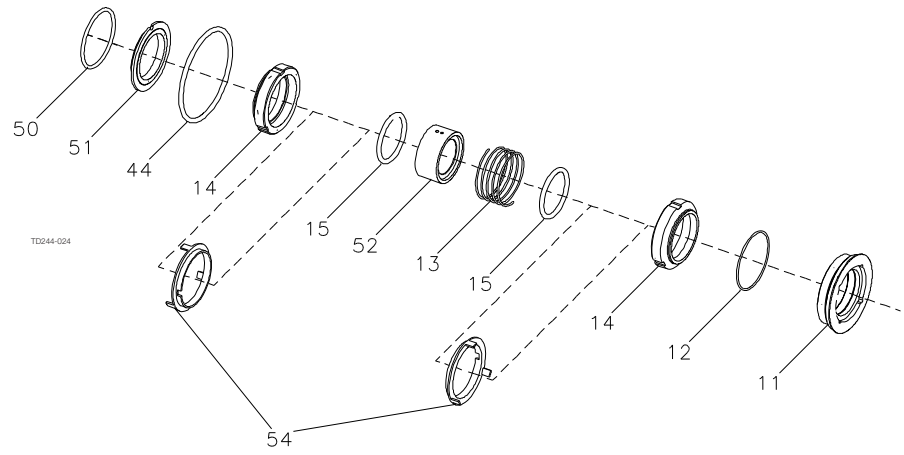

The drawing shows the LKH_{Hex}, sanitary version.

Always use Alfa Laval genuine spare parts.

Always refer to the pump serial no. on the name plate when ordering spare parts to ensure correct spares.

Parts list

Pos.	Qty	Denomination
10	1	SiC/SiC SiC/SiC Drive ring
11	1	Stationary seal ring
12	1	O-ring
13	1	Spring
14	1	Rotating seal ring
15	1	O-ring
40a	1	Seal housing
41	2	Screw for seal housing
42	2	Tube
44	1	O-ring for seal housing
50	1	O-ring
51	1	Sec. stationary seal ring
52	1	Drive ring

Service kits

Denomination	EPDM	NBR	FPM	FEP
Service kit for single shaft seal C/SiC				
□ Service kit, C/SiC (LKH-10/15)	9611922072	9611922073	9611922074	9611922075
□ Service kit, C/SiC (LKH-20)	9611922080	9611922081	9611922082	9611922083
□ Service kit, C/SiC (LKH-25/35/45)	9611922178	9611922179	9611922180	9611922181
□ Service kit, C/SiC (LKH-40/50/60)	9611922088	9611922089	9611922090	9611922091
Service kit for single shaft seal SiC/SiC				
◇ Service kit, SiC/SiC (LKH-10/15)	9611922546	9611922547	9611922548	9611922549
◇ Service kit, SiC/SiC (LKH-20)	9611922570	9611922571	9611922572	9611922573
◇ Service kit, SiC/SiC (LKH-25/35/45)	9611922594	9611922595	9611922596	9611922597
◇ Service kit, SiC/SiC (LKH-40/50/60)	9611922619	9611922620	9611922621	9611922622
Service kit for single shaft seal and impeller screw C/SiC				
◆ Service kit, C/SiC (LKH-10/15)	9611922114	9611922115	9611922116	9611922117
◆ Service kit, C/SiC (LKH-20)	9611922122	9611922123	9611922124	9611922125
◆ Service kit, C/SiC (LKH-25/35/45)	9611922182	9611922183	9611922184	9611922185
◆ Service kit, C/SiC (LKH-40/50/60)	9611922130	9611922131	9611922132	9611922133
◆ Service kit, C/SiC (LKH-70)	9611922238	9611922239	9611922240	9611922241
Service kit for single shaft seal and impeller screw SiC/SiC				
◇ Service kit, SiC/SiC (LKH-10/15)	9611922550	9611922551	9611922552	9611922553
◇ Service kit, SiC/SiC (LKH-20)	9611922574	9611922575	9611922576	9611922577
◇ Service kit, SiC/SiC (LKH-25/35/45)	9611922598	9611922599	9611922600	9611922601
◇ Service kit, SiC/SiC (LKH-40/50/60)	9611922623	9611922624	9611922625	9611922626
◇ Service kit, SiC/SiC (LKH-70)	9611922643	9611922644	9611922645	9611922646
Service kit for double mechanical shaft seal C/SiC				
△ Service kit, C/SiC (LKH-10/15)	9611922206	9611922207	9611922208	9611922209
△ Service kit, C/SiC (LKH-20)	9611922214	9611922215	9611922216	9611922217
△ Service kit, C/SiC (LKH-25/35/45)	9611922222	9611922223	9611922224	9611922225
△ Service kit, C/SiC (LKH-40/50/60)	9611922230	9611922231	9611922232	9611922233

7 Parts list

The drawing shows the LKHex, sanitary version.

Always use Alfa Laval genuine spare parts.

Always refer to the pump serial no. on the name plate when ordering spare parts to ensure correct spares.

Denomination	EPDM	NBR	FPM	FEP
Service kit for double mechanical shaft seal SiC/SiC				
* Service kit, SiC/SiC (LKH-10/15)	9611922562	9611922563	9611922564	9611922565
* Service kit, SiC/SiC (LKH-20)	9611922586	9611922587	9611922588	9611922589
* Service kit, SiC/SiC (LKH-25/35/45)	9611922610	9611922611	9611922612	9611922613
* Service kit, SiC/SiC (LKH-40/50/60)	9611922635	9611922636	9611922637	9611922638
Service kit for double mechanical shaft seal and impeller screw C/SiC				
▲ Service kit, C/SiC (LKH-10/15)	9611922210	9611922211	9611922212	9611922213
▲ Service kit, C/SiC (LKH-20)	9611922218	9611922219	9611922220	9611922221
▲ Service kit, C/SiC (LKH-25/35/45)	9611922226	9611922227	9611922228	9611922229
▲ Service kit, C/SiC (LKH-40/50/60)	9611922234	9611922235	9611922236	9611922237
▲ Service kit, C/SiC (LKH-70)	9611922416	9611922417	9611922418	9611922419
Service kit for double mechanical shaft seal and impeller screw SiC/SiC				
• Service kit, SiC/SiC (LKH-10/15)	9611922566	9611922567	9611922568	9611922569
• Service kit, SiC/SiC (LKH-20)	9611922590	9611922591	9611922592	9611922593
• Service kit, SiC/SiC (LKH-25/35/45)	9611922614	9611922615	9611922616	9611922617
• Service kit, SiC/SiC (LKH-40/50/60)	9611922639	9611922640	9611922641	9611922642
• Service kit, SiC/SiC (LKH-70)	9611922651	9611922652	9611922653	9611922654

Parts marked with □♦★▲◆◇■※◎● are included in the service kits.

Recommended spare parts: Service kits.

Conversion kit - single to double mechanical shaft seal: Please order double mechanical service kit + pos. 40a + 41 + 42

(900629/12)

How to contact Alfa Laval

Contact details for all countries are continually updated on our website.

Please visit www.alfalaval.com to access the information directly.

© Alfa Laval Corporate AB

This document and its contents is owned by Alfa Laval Corporate AB and protected by laws governing intellectual property and thereto related rights. It is the responsibility of the user of this document to comply with all applicable intellectual property laws. Without limiting any rights related to this document, no part of this document may be copied, reproduced or transmitted in any form or by any means (electronic, mechanical, photocopying, recording, or otherwise), or for any purpose, without the expressed permission of Alfa Laval Corporate AB. Alfa Laval Corporate AB will enforce its rights related to this document to the fullest extent of the law, including the seeking of criminal prosecution.